

AX5043

Advanced High Performance ASK and FSK Narrow-band Transceiver for 27 - 1050 MHz Range



ON Semiconductor®

www.onsemi.com

OVERVIEW

Features

Advanced Multi-channel Narrow-band Single Chip UHF Transceiver (FSK/MSK/4-FSK/GFSK/GMSK/ASK/AFSK/FM/PSK)

Low-Power

- RX
 - 9.5 mA @ 868 MHz and 433 MHz
 - 6.5 mA @ 169 Hz
- TX at 868 Mhz
 - 7.5 mA @ 0 dBm
 - 16 mA @ 10 dBm
 - 48 mA @ 16 dBm
- 50 nA Deep Sleep Current
- 500 nA Power-down Current with Low Frequency Duty Cycle Clock Running

Extended Supply Voltage Range

- 1.8 V – 3.6 V Single Supply

High Sensitivity / High Selectivity Receiver

- Data Rates from 0.1 kbps to 125 kbps
- Optional Forward Error Correction (FEC)
- Sensitivity without FEC
 - 135 dBm @ 0.1 kbps, 868 MHz, FSK
 - 126 dBm @ 1 kbps, 868 MHz, FSK
 - 117 dBm @ 10 kbps, 868 MHz, FSK
 - 107 dBm @ 100 kbps, 868 MHz, FSK
 - 105 dBm @ 125 kbps, 868 MHz, FSK

 - 138 dBm @ 0.1 kbps, 868 MHz, PSK
 - 130 dBm @ 1 kbps, 868 MHz, PSK
 - 120 dBm @ 10 kbps, 868 MHz, PSK
 - 109 dBm @ 100 kbps, 868 MHz, PSK
 - 108 dBm @ 125 kbps, 868 MHz, PSK
- Sensitivity with FEC
 - 137 dBm @ 0.1 kbps, 868 MHz, FSK
 - 122 dBm @ 5 kbps, 868 MHz, FSK
 - 111 dBm @ 50 kbps, 868 MHz, FSK
- High Selectivity Receiver with up to 47 dB Adjacent Channel Rejection

- 0 dBm Maximum Input Power
- > ±10% Data-rate Error Tolerance
- Support for Antenna Diversity with External Antenna Switch
- Short Preamble Modes allow the Receiver to work with as little as 16 Preamble Bits
- Fast State Switching Times
 - 200 μs TX → RX Switching Time
 - 62 μs RX → TX Switching Time

Transmitter

- Data-rates from 0.1 kbps to 125 kbps
- High Efficiency, High Linearity Integrated Power Amplifier
- Maximum Output Power
 - 16 dBm @ 868 MHz
 - 16 dBm @ 433 MHz
 - 16 dBm @ 169 MHz
- Power Level programmable in 0.5 dB Steps
- GFSK Shaping with BT = 0.3 or BT = 0.5
- Unrestricted Power Ramp Shaping

Frequency Generation

- Configurable for Usage in 27 MHz –1050 MHz Bands
- RF Carrier Frequency and FSK Deviation Programmable in 1 Hz Steps
- Ultra Fast Settling RF Frequency Synthesizer for Low-power Consumption
- Fully Integrated RF Frequency Synthesizer with VCO Auto-ranging and Band-width Boost Modes for Fast Locking
- Configurable for either Fully Integrated VCO, Internal VCO with External Inductor or Fully External VCO
- Configurable for either Fully Integrated or External Synthesizer Loop Filter for a Large Range of Bandwidths
- Channel Hopping up to 2000 hops/s
- Automatic Frequency Control (AFC)

AX5043

Flexible Antenna Interface

- Integrated RX/TX Switching with Differential Antenna Pins
- Mode with Differential RX Pins and Single-ended TX Pin for Usage with External PAs and for Maximum PA Efficiency at Low Output Power

Wakeup-on-Radio

- 640 Hz or 10 kHz Lowest Power Wake-up Timer
- Wake-up Time Interval programmable between 98 μ s and 102 s

Sophisticated Radio Controller

- Antenna Diversity and Optional External RX/TX Switch Control
- Fully Automatic Packet Reception and Transmission without Micro-controller Intervention
- Supports HDLC, Raw, Wireless M-Bus Frames and Arbitrary Defined Frames
- Automatic Channel Noise Level Tracking
- μ s Resolution Timestamps for Exact Timing (eg. for Frequency Hopping Systems)
- 256 Byte Micro-programmable FIFO, optionally supports Packet Sizes > 256 Bytes
- Three Matching Units for Preamble Byte, Sync-word and Address
- Ability to store RSSI, Frequency Offset and Data-rate Offset with the Packet Data
- Multiple Receiver Parameter Sets allow the use of more aggressive Receiver Parameters during Preamble, dramatically shortening the Required Preamble Length at no Sensitivity Degradation

Advanced Crystal Oscillator (RF Reference Oscillator)

- Fast Start-up and Lowest Power Steady-state XTAL Oscillator for a Wide Range of Crystals
- Integrated Crystal Tuning Capacitors
- Possibility of Applying an External Clock Reference (TCXO)

Miscellaneous Features

- Few External Components
- SPI Microcontroller Interface
- Extended AXSEM Register Set
- Fully Integrated Current/Voltage References
- QFN28 5 mm x 5 mm Package
- Internal Power-on-Reset
- Brown-out Detection
- 10 Bit 1 MS/s General Purpose ADC (GPADC)

Applications

27 – 1050 MHz Licensed and Unlicensed Radio Systems

- Internet of Things
- Automatic Meter Reading (AMR)
- Security Applications
- Building Automation
- Wireless Networks
- Messaging Paging
- Compatible with: Wireless M-Bus, POCSAG, FLEX, KNX, Sigfox, Z-Wave, enocean
- Regulatory Regimes: EN 300 220 V2.3.1 including the Narrow-band 12.5 kHz, 20 kHz and 25 kHz Definitions; EN 300 422; FCC Part 15.247; FCC Part 15.249; FCC Part 90 6.25 kHz, 12.5 kHz and 25 kHz

AX5043

BLOCK DIAGRAM

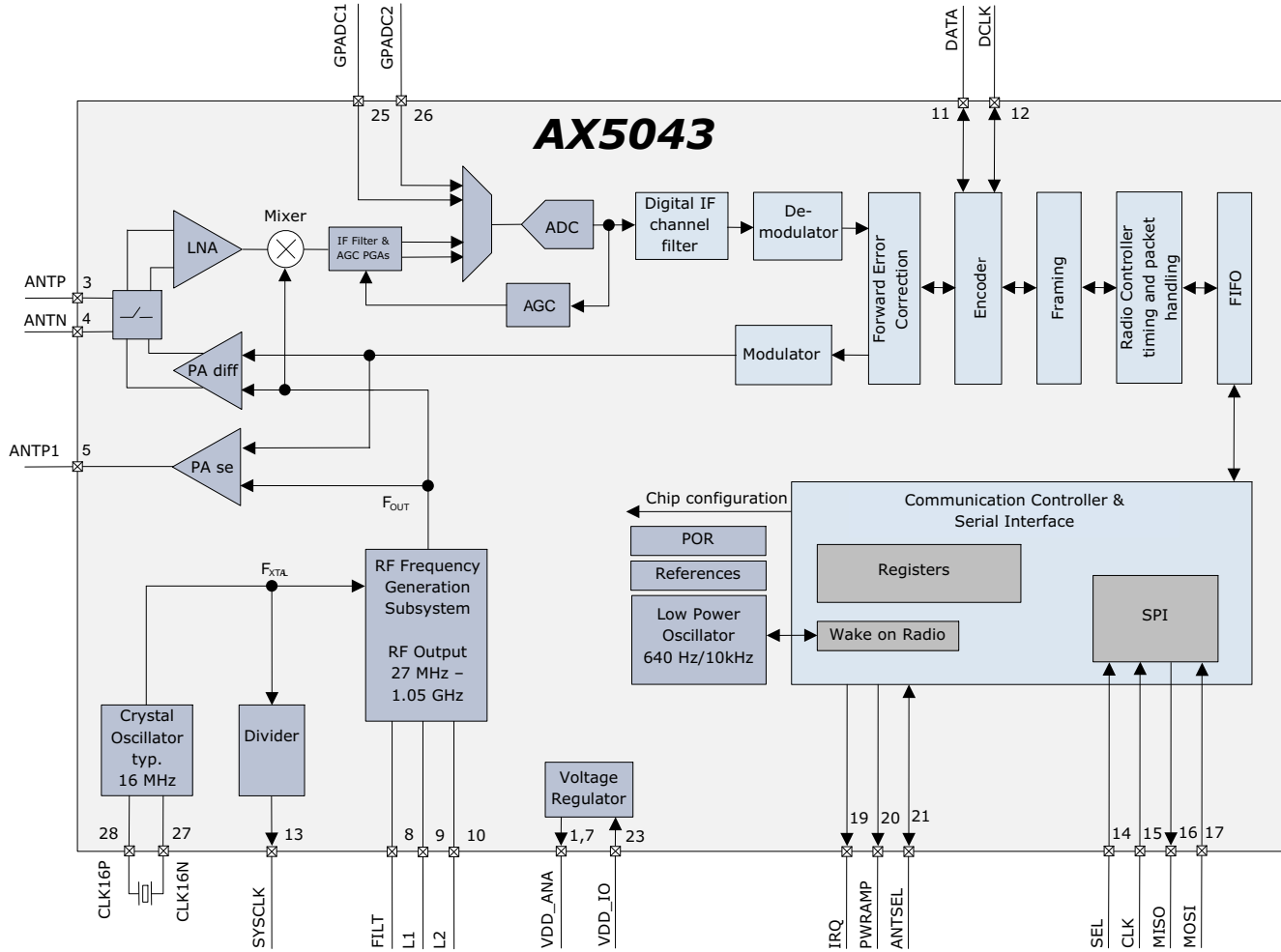

Figure 1. Functional Block Diagram of the AX5043

AX5043

Table 1. PIN FUNCTION DESCRIPTIONS

Symbol	Pin(s)	Type	Description
VDD_ANA	1	P	Analog power output, decouple to neighboring GND
GND	2	P	Ground, decouple to neighboring VDD_ANA
ANTP	3	A	Differential antenna input/output
ANTN	4	A	Differential antenna input/output
ANTP1	5	A	Single-ended antenna output
GND	6	P	Ground, decouple to neighboring VDD_ANA
VDD_ANA	7	P	Analog power output, decouple to neighboring GND
FILT	8	A	Optional synthesizer filter
L2	9	A	Optional synthesizer inductor, should be shorted with L1 if not used.
L1	10	A	Optional synthesizer inductor, should be shorted with L2 if not used.
DATA	11	I/O	In wire mode: Data input/output Can be programmed to be used as a general purpose I/O pin Selectable internal 65 k Ω pull-up resistor
DCLK	12	I/O	In wire mode: Clock output Can be programmed to be used as a general purpose I/O pin Selectable internal 65 k Ω pull-up resistor
SYSCLK	13	I/O	Default functionality: Crystal oscillator (or divided) clock output Can be programmed to be used as a general purpose I/O pin Selectable internal 65 k Ω pull-up resistor
SEL	14	I	Serial peripheral interface select
CLK	15	I	Serial peripheral interface clock
MISO	16	O	Serial peripheral interface data output
MOSI	17	I	Serial peripheral interface data input
NC	18	N	Must be left unconnected
IRQ	19	I/O	Default functionality: Transmit and receive interrupt Can be programmed to be used as a general purpose I/O pin Selectable internal 65 k Ω pull-up resistor
PWRAMP	20	I/O	Default functionality: Power amplifier control output Can be programmed to be used as a general purpose I/O pin Selectable internal 65 k Ω pull-up resistor
ANTSEL	21	I/O	Default functionality: Diversity antenna selection output Can be programmed to be used as a general purpose I/O pin Selectable internal 65 k Ω pull-up resistor
NC	22	N	Must be left unconnected
VDD_IO	23	P	Power supply 1.8 V – 3.3 V
NC	24	N	Must be left unconnected
GPADC1	25	A	GPADC input, must be connected to GND if not used
GPADC2	26	A	GPADC input, must be connected to GND if not used
CLK16N	27	A	Crystal oscillator input/output
CLK16P	28	A	Crystal oscillator input/output
GND	Center pad	P	Ground on center pad of QFN, must be connected

A = analog input
 I = digital input signal
 O = digital output signal
 I/O = digital input/output signal
 N = not to be connected
 P = power or ground

All digital inputs are Schmitt trigger inputs, digital input and output levels are LVCMOS/LVTTL compatible and 5 V tolerant.

AX5043

Pinout Drawing

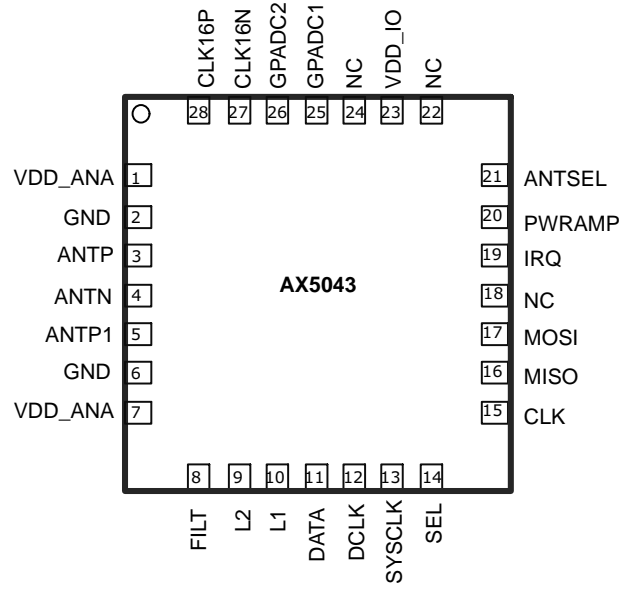

Figure 2. Pinout Drawing (Top View)

SPECIFICATIONS

Table 2. ABSOLUTE MAXIMUM RATINGS

Symbol	Description	Condition	Min	Max	Units
VDD_IO	Supply voltage		-0.5	5.5	V
IDD	Supply current			200	mA
P _{tot}	Total power consumption			800	mW
P _i	Absolute maximum input power at receiver input	ANTP and ANTN pins in RX mode		10	dBm
I _{I1}	DC current into any pin except ANTP, ANTN, ANTP1		-10	10	mA
I _{I2}	DC current into pins ANTP, ANTN, ANTP1		-100	100	mA
I _O	Output Current			40	mA
V _{ia}	Input voltage ANTP, ANTN, ANTP1 pins		-0.5	5.5	V
	Input voltage digital pins		-0.5	5.5	V
V _{es}	Electrostatic handling	HBM	-2000	2000	V
T _{amb}	Operating temperature		-40	85	°C
T _{stg}	Storage temperature		-65	150	°C
T _j	Junction Temperature			150	°C

Stresses exceeding those listed in the Maximum Ratings table may damage the device. If any of these limits are exceeded, device functionality should not be assumed, damage may occur and reliability may be affected.

1. Exposure to absolute maximum rating conditions for extended periods may affect device reliability.

DC Characteristics

Table 3. SUPPLIES

Symbol	Description	Condition	Min	Typ	Max	Units
T _{AMB}	Operational ambient temperature		-40	27	85	°C
VDD_IO	I/O and voltage regulator supply voltage		1.8	3.0	3.6	V
V _{BOUT}	Brown-out threshold	Note 1		1.3		V
I _{DSLLEP}	Deep Sleep current: All analog and digital functions are powered down	PWRMODE = 0x01		50		nA
I _{PDOWN}	Power-down current: Register file contents preserved	PWRMODE = 0x00		400		nA
I _{WOR}	Wakeup-on-radio mode: Low power timer and WOR state-machine are running at 640 Hz	PWRMODE = 0x0B		500		nA
I _{STANBY}	Standby-current: All power domains are powered up, crystal oscillator and references are running	PWRMODE = 0x05		230		μA
I _{RX}	Current consumption RX PWRMODE = 0x09 RF Frequency Subsystem: Internal VCO and internal loop-filter	868 MHz, datarate 6 kbps		9.5		mA
		169 MHz, datarate 6 kbps		6.5		
		868 MHz, datarate 100 kbps		11		
		169 MHz, datarate 100 kbps		7.5		

1. Digital circuitry is functional down to typically 1 V.
2. Measured with optimized matching networks.

Table 3. SUPPLIES

Symbol	Description	Condition	Min	Typ	Max	Units
I _{TX-DIFF}	Current consumption TX differential	868 MHz, 16 dBm, FSK, Note 2 RF Frequency Subsystem: Internal VCO and loop-filter Antenna configuration: Differential PA		48		mA
I _{TX-SE}	Current consumption TX single ended	868 MHz, 0 dBm, FSK, RF Frequency Subsystem: Internal VCO and loop-filter Antenna configuration: Single ended PA, external RX/TX switching		7.5		mA

1. Digital circuitry is functional down to typically 1 V.
2. Measured with optimized matching networks.

For information on current consumption in complex modes of operation tailored to your application, see the software AX-RadioLab for AX5043.

Note on current consumption in TX mode

To achieve best output power the matching network has to be optimized for the desired output power and frequency. As a rule of thumb a good matching network produces about 50% efficiency with the AX5043 power amplifier although over 90% are theoretically possible. A typical matching network has between 1 dB and 2 dB loss (P_{loss}). The theoretical efficiencies are the same for the single ended PA (ANTP1) and differential PA (ANTP and ANTN) therefore only one current value is shown in the table below. We recommend to use the single ended PA for low output power and the differential PA for high power. The differential PA is internally multiplexed with the LNA on pins ANTP and ANTN. Therefore constraints for the RX matching have to be considered for the differential PA matching.

The current consumption can be calculated as

$$I_{TX}[mA] = \frac{1}{PA_{efficiency}} \times 10^{\frac{P_{out}[dBm] + P_{loss}[dB]}{10}} \div 1.8V + I_{offset}$$

I_{offset} is about 6 mA for the fully integrated VCO at 400 MHz to 1050 MHz, and 3 mA for the VCO with external inductor at 169 MHz. The following table shows calculated current consumptions versus output power for P_{loss} = 1 dB, PA_{efficiency} = 0.5, I_{offset} = 6 mA at 868 MHz and I_{offset} = 3.5 mA at 169 MHz.

Table 4. CURRENT CONSUMPTION VS. OUTPUT POWER

Pout [dBm]	I _{txcalc} [mA]	
	868 MHz	169 MHz
0	7.5	4.5
1	7.9	4.9
2	8.4	5.4
3	9.0	6.0
4	9.8	6.8
5	10.8	7.8
6	12.1	9.1
7	13.7	10.7
8	15.7	12.7
9	18.2	15.2
10	21.3	18.3
11	25.3	22.3
12	30.3	27.3
13	36.7	33.7
14	44.6	41.6
15	54.6	51.6

Both AX5043 power amplifiers run from the regulated VDD_ANA supply and not directly from the battery. This has the advantage that the current and output power do not vary much over supply voltage and temperature.

Table 5. LOGIC

Symbol	Description	Condition	Min	Typ	Max	Units
Digital Inputs						
V_{T+}	Schmitt trigger low to high threshold point			1.9		V
V_{T-}	Schmitt trigger high to low threshold point			1.2		V
V_{IL}	Input voltage, low				0.8	V
V_{IH}	Input voltage, high		2.0			V
I_L	Input leakage current		-10		10	μ A
R_{pullup}	Pull-up resistors Pins DATA, DCLK, SYSCLK, IRQ, PWRAMP, ANTSEL	Pull-ups enabled in the relevant pin configuration registers		65		k Ω

Digital Outputs

I_{OH}	Output Current, high	$V_{DD_IO} = 3\text{ V}$ $V_{OH} = 2.4\text{ V}$	4			mA
I_{OL}	Output Current, low	$V_{DD_IO} = 3\text{ V}$ $V_{OL} = 0.4\text{ V}$	4			mA
I_{OZ}	Tri-state output leakage current		-10		10	μ A

AC Characteristics

Table 6. CRYSTAL OSCILLATOR

Symbol	Description	Condition	Min	Typ	Max	Units
f_{XTAL}	Crystal frequency	Note 1, 2, 3	10	16	50	MHz
$g_{m_{osc}}$	Oscillator transconductance control range	Self-regulated see note 4	0.2		20	mS
C_{osc}	Programmable tuning capacitors at pins CLK16N and CLK16P	XTALCAP = 0x00 default		3		pF
		XTALCAP = 0x01		8.5		pF
		XTALCAP = 0xFF		40		pF
$C_{osc-lsb}$	Programmable tuning capacitors, increment per LSB of XTALCAP	XTALCAP = 0x01 – 0xFF		0.5		pF
f_{ext}	External clock input (TCXO)	Note 2, 3, 5	10	16	50	MHz
$R_{IN_{osc}}$	Input DC impedance		10			k Ω
$NDIV_{SYSCLK}$	Divider ratio $f_{SYSCLK} = f_{XTAL} / NDIV_{SYSCLK}$		2^0	2^4	2^{10}	

1. Tolerances and start-up times depend on the crystal used. Depending on the RF frequency and channel spacing the IC must be calibrated to the exact crystal frequency using the readings of the register TRKFREQ.
2. The choice of crystal oscillator or TCXO frequency depends on the targeted regulatory regime for TX, see separate documentation on meeting regulatory requirements.
3. To avoid spurious emission, the crystal or TCXO reference frequency should be chosen so that the RF carrier frequency is not an integer multiple of the crystal or TCXO frequency.
4. The oscillator transconductance is regulated for fastest start-up time during start-up and for lowest power during steady state oscillation. This means that values depend on the crystal used.
5. If an external clock or TCXO is used, it should be input via an AC coupling at pin CLK16P with the oscillator powered up and XTALCAP = 0x00. For detailed TCXO network recommendations depending on the TCXO output swing refer to the AX5043 Application Note: Use with a TCXO Reference Clock.

Table 7. LOW-POWER OSCILLATOR

Symbol	Description	Condition	Min	Typ	Max	Units
$f_{osc-slow}$	Oscillator frequency slow mode LPOSC FAST = 0	No calibration	480	640	800	Hz
		Internal calibration vs. crystal clock has been performed	630	640	650	
$f_{osc-fast}$	Oscillator frequency fast mode LPOSC FAST = 1	No calibration	7.6	10.2	12.8	kHz
		Internal calibration vs. crystal clock has been performed	9.8	10.2	10.8	

Table 8. RF FREQUENCY GENERATION SUBSYSTEM (SYNTHESIZER)

Symbol	Description	Condition	Min	Typ	Max	Units
f_{REF}	Reference frequency	The reference frequency must be chosen so that the RF carrier frequency is not an integer multiple of the reference frequency	10	16	50	MHz

Dividers

$NDIV_{ref}$	Reference divider ratio range	Controlled directly with register REFDIV	2^0		2^3	
$NDIV_m$	Main divider ratio range	Controlled indirectly with register FREQ	4.5		66.5	
$NDIV_{RF}$	RF divider range	Controlled directly with register RFDIV	1		2	

Charge Pump

I_{CP}	Charge pump current	Programmable in increments of 8.5 μ A via register PLLCPI	8.5		2168	μ A
----------	---------------------	---------------------------------------------------------------	-----	--	------	---------

Internal VCO (VCOSEL = 0)

f_{RF}	RF frequency range	RFDIV = 1	400		525	MHz
		RFDIV = 0	800		1050	
f_{step}	RF frequency step	RFDIV = 1, $f_{xtal} = 16.000000$ MHz		0.98		Hz
BW	Synthesizer loop bandwidth	The synthesizer loop bandwidth and start-up time can be programmed with registers PLLLOOP and PLLCPI. For recommendations see the AX5043 Programming Manual, the AX-RadioLab software and AX5043 Application Notes on compliance with regulatory regimes.	50		500	kHz
T_{start}	Synthesizer start-up time if crystal oscillator and reference are running		5		25	μ s
PN868	Synthesizer phase noise 868 MHz $f_{REF} = 48$ MHz	10 kHz offset from carrier		-95		dBc/Hz
		1 MHz offset from carrier		-120		
PN433	Synthesizer phase noise 433 MHz $f_{REF} = 48$ MHz	10 kHz offset from carrier		-105		dBc/Hz
		1 MHz offset from carrier		-120		

VCO with external inductors (VCOSEL = 1, VCO2INT = 1)

f_{RFmg_lo}	RF frequency range For choice of L_{ext} values as well as VCO gains see Figure 3 and Figure 4	RFDIV = 1	27		262	MHz
f_{RFmg_hi}		RFDIV = 0	54		525	
PN169	Synthesizer phase noise 169 MHz $L_{ext}=47$ nH (wire wound 0603) RFDIV = 0, $f_{REF}= 16$ MHz Note: phase noises can be improved with higher f_{REF}	10 kHz from carrier		-97		dBc/Hz
		1 MHz from carrier		-115		

External VCO (VCOSEL = 1, VCO2INT = 0)

f_{RF}	RF frequency range fully external VCO	Note: The external VCO frequency needs to be $2 \times f_{RF}$	27		1000	MHz
V_{amp}	Differential input amplitude at L1, L2 terminals			0.7		V
V_{inL}	Input voltage levels at L1, L2 terminals		0		1.8	V
V_{ctrl}	Control voltage range	Available at FILT in external loop filter mode	0		1.8	V

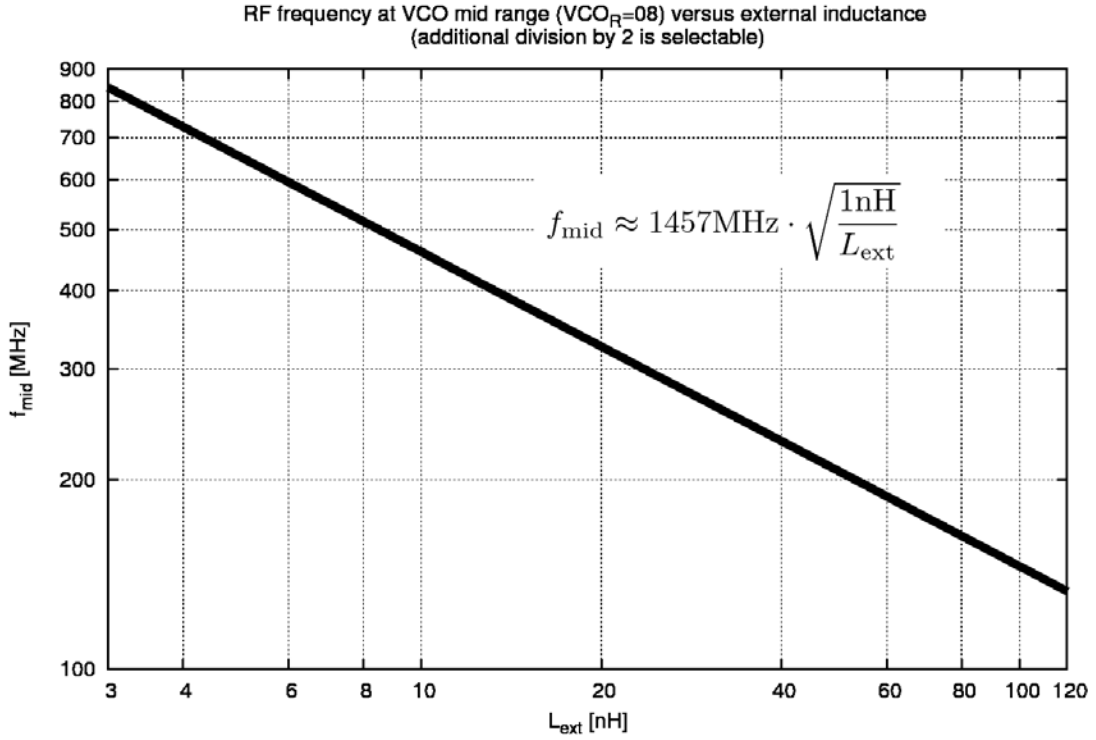

Figure 3. VCO with External Inductors: Typical Frequency vs. L_{ext}

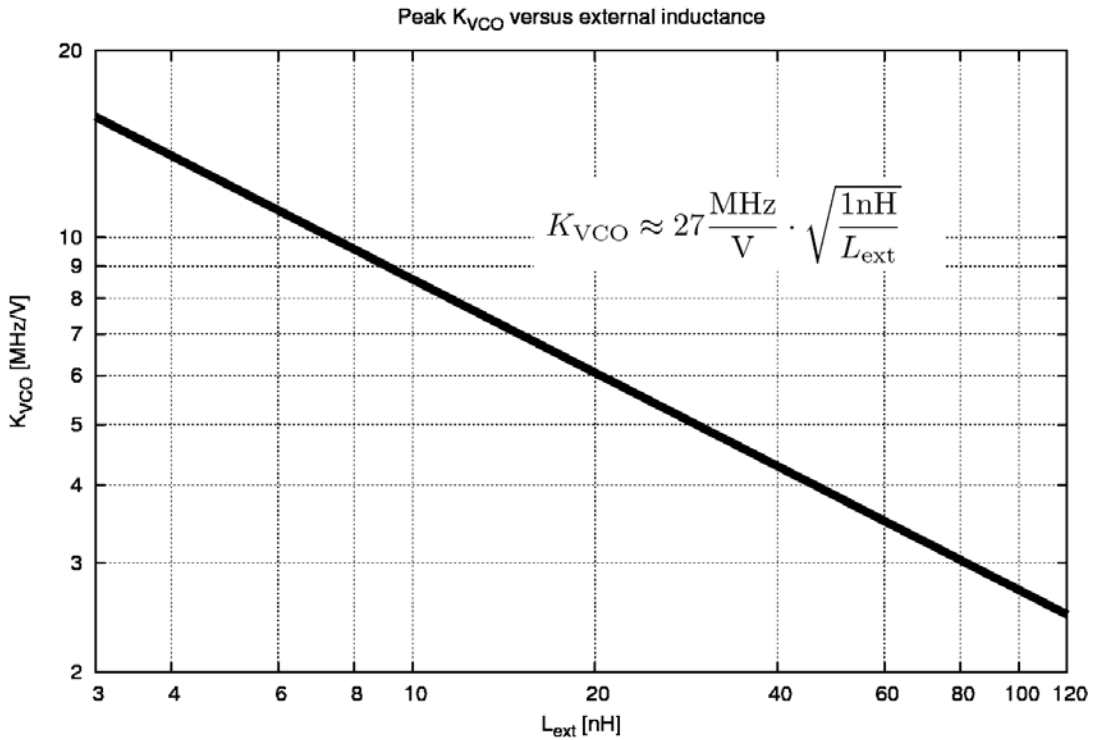

Figure 4. VCO with External Inductors: Typical K_{VCO} vs. L_{ext}

AX5043

The following table shows the typical frequency ranges for frequency synthesis with external VCO inductor for different inductor values.

Table 9.

Lext [nH]	Freq [MHz] RFDIV = 0	Freq [MHz] RFDIV = 1	PLL Range
8.2	482	241	0
8.2	437	219	15
10	432	216	0
10	390	195	15
12	415	208	0
12	377	189	15
15	380	190	0
15	345	173	15
18	345	173	0
18	313	157	15
22	308	154	0
22	280	140	14
27	285	143	0
27	258	129	15

33	260	130	0
33	235	118	15
39	245	123	0
39	223	112	14
47	212	106	0
47	194	97	14
56	201	101	0
56	182	91	15
68	178	89	0
68	161	81	15
82	160	80	1
82	146	73	14
100	149	75	1
100	136	68	14
120	136	68	0
120	124	62	14

For tuning or changing of ranges a capacitor can be added in parallel to the inductor.

Table 10. TRANSMITTER

Symbol	Description	Condition	Min	Typ	Max	Units
SBR	Signal bit rate		0.1		125	kbps
PTX	Transmitter power @ 868 MHz	Differential PA, 50 Ω single ended measurement at an SMA connector behind the matching network, Note 2	-10		16	dBm
	Transmitter power @ 433 MHz		-10		16	
	Transmitter power @ 169 MHz		-10		16	
PTX _{step}	Programming step size output power	Note 1			0.5	dB
dTX _{temp}	Transmitter power variation vs. temperature	-40°C to +85°C Note 2		± 0.5		dB
dTX _{Vdd}	Transmitter power variation vs. VDD_IO	1.8 to 3.6 V Note 2		± 0.5		dB
Padj	Adjacent channel power GFSK BT = 0.5, 500 Hz deviation, 1.2 kbps, 25 kHz channel spacing, 10 kHz channel BW	868 MHz		-44		dBc
		433 MHz		-51		
PTX _{868-harm2}	Emission @ 2 nd harmonic	868 MHz, Note 2		-40		dBc
PTX _{868-harm3}	Emission @ 3 rd harmonic			-60		
PTX _{433-harm2}	Emission @ 2 nd harmonic	433 MHz, Note 2		-40		dBc
PTX _{433-harm3}	Emission @ 3 rd harmonic			-40		

$$1. P_{out} = \frac{TXPWRCOEFFB}{2^{12} - 1} \times P_{max}$$

- 50 Ω single ended measurements at an SMA connector behind the matching network. For recommended matching networks see section: Application Information.

Table 11. RECEIVER SENSITIVITIES

The table lists typical input sensitivities (without FEC) in dBm at the SMA connector with the complete matching network for BER=10⁻³ at 433 or 868 MHz.

Data rate [kbps]		FSK h = 0.66	FSK h = 1	FSK h = 2	FSK h = 4	FSK h = 5	FSK h = 8	FSK h = 16	PSK
0.1	Sensitivity [dBm]	-135	-134.5	-132.5	-133	-133.5	-133	-132.5	-138
	RX Bandwidth [kHz]	0.2	0.2	0.3	0.5	0.6	0.9	2.1	0.2
	Deviation [kHz]	0.033	0.05	0.1	0.2	0.25	0.4	0.8	
1	Sensitivity [dBm]	-126	-125	-123	-123.5	-124	-123.5	-122.5	-130
	RX Bandwidth [kHz]	1.5	2	3	6	7	11	21	1
	Deviation [kHz]	0.33	0.5	1	2	2.5	4	8	
10	Sensitivity [dBm]	-117	-116	-113	-114	-113.5	-113		-120
	RX Bandwidth [kHz]	15	20	30	50	60	110		10
	Deviation [kHz]	3.3	5	10	20	25	40		
100	Sensitivity [dBm]	-107	-105.5						-109
	RX Bandwidth [kHz]	150	200						100
	Deviation [kHz]	33	50						
125	Sensitivity [dBm]	-105	-104						-108
	RX Bandwidth [kHz]	187.5	200						125
	Deviation [kHz]	42.3	62.5						

- Sensitivities are equivalent for 1010 data streams and PN9 whitened data streams.
- RX bandwidths < 0.9 kHz cannot be achieved with an 48 MHz TCXO. A 16 MHz TCXO was used for all measurements at 0.1 kbps.

AX5043

Table 12. RECEIVER

Symbol	Description	Condition	Min	Typ	Max	Units
SBR	Signal bit rate		0.1		125	kbps
IS _{BER868}	Input sensitivity at BER = 10 ⁻³ for 868 MHz operation, continuous data, without FEC	FSK, h = 0.5, 100 kbps		-106		dBm
		FSK, h = 0.5, 10 kbps		-116		
		FSK, 500 Hz deviation, 1.2 kbps		-126		
		PSK, 100 kbps		-109		
		PSK, 10 kbps		-120		
		PSK, 1 kbps		-130		
IS _{BER868FEC}	Input sensitivity at BER = 10 ⁻³ , for 868 MHz operation, continuous data, with FEC	FSK, h = 0.5, 50 kbps		-111		dBm
		FSK, h = 0.5, 5 kbps		-122		
		FSK, 500 Hz deviation, 0.1 kbps		-137		
IS _{PER868}	Input sensitivity at PER = 1%, for 868 MHz operation, 144 bit packet data, without FEC	FSK, h = 0.5, 100 kbps		-103		dBm
		FSK, h = 0.5, 10 kbps		-115		
		FSK, 1.2 kbps		-125		
IS _{WOR868}	Input sensitivity at PER = 1% for 868 MHz operation, 144 bit packet data, WOR-mode, without FEC	FSK, h = 0.5, 100 kbps		-102		dBm
IL	Maximum input level	Full selectivity		0		dBm
IL _{max}	Maximum input level	FSK, reduced selectivity		10		
CP _{1dB}	Input referred compression point	2 tones separated by 100 kHz		-35		dBm
RSSIR	RSSI control range	FSK, 500 Hz deviation, 1.2 kbps	-126		-46	dB
RSSIS ₁	RSSI step size	Before digital channel filter; calculated from register AGCCOUNTER		0.625		dB
RSSIS ₂	RSSI step size	Behind digital channel filter; calculated from registers AGCCOUNTER, TRKAMPL		0.1		dB
RSSIS ₃	RSSI step size	Behind digital channel filter; reading register RSSI		1		dB
SEL ₈₆₈	Adjacent channel suppression	25 kHz channels , Note 1		45		dB
		100 kHz channels, Note 1		47		
BLK ₈₆₈	Blocking at ± 10 MHz offset	Note 2		78		dB
RAFC	AFC pull-in range	The AFC pull-in range can be programmed with the MAXRFOFFSET registers. The AFC response time can be programmed with the FREQGAIN register.	± 15			%
RDROFF	Bitrate offset pull-in range	The bitrate pull-in range can be programmed with the MAXDROFFSET registers.	± 10			%

1. Interferer/Channel @ BER = 10⁻³, channel level is +3 dB above the typical sensitivity, the interfering signal is CW; channel signal is modulated with shaping
2. Channel/Blocker @ BER = 10⁻³, channel level is +3 dB above the typical sensitivity, the blocker signal is CW; channel signal is modulated with shaping

Table 13. RECEIVER AND TRANSMITTER SETTLING PHASES

Symbol	Description	Condition	Min	Typ	Max	Units
T _{x_{tal}}	XTAL settling time	Powermodes: POWERDOWN to STANDBY Note that T _{x_{tal}} depends on the specific crystal used.		0.5		ms
T _{synth}	Synthesizer settling time	Powermodes: STANDBY to SYNTHTX or SYNTHRX		40		μs
T _{tx}	TX settling time	Powermodes: SYNTHTX to FULLTX T _{tx} is the time used for power ramping, this can be programmed to be 1 x t _{bit} , 2 x t _{bit} , 4 x t _{bit} or 8 x t _{bit} . Notes 1, 2	0	1 x t _{bit}	8 x t _{bit}	μs
T _{rx_init}	RX initialization time			150		μs
T _{rx_rssi}	RX RSSI acquisition time (after T _{rx_init})	Powermodes: SYNTHRX to FULLRX		80 + 3 x t _{bit}		μs
T _{rx_preamble}	RX signal acquisition time to valid data RX at full sensitivity/selectivity (after T _{rx_init})	Modulation (G)FSK Notes 1, 2		9 x t _{bit}		μs

1. t_{bit} depends on the datarate, e.g. for 10 kbps t_{bit} = 100 μs
2. In wire mode there is a processing delay of typically 6 x t_{bit} between antenna and DCLK/DATA pins

Table 14. OVERALL STATE TRANSITION TIMES

Symbol	Description	Condition	Min	Typ	Max	Units
T _{tx_on}	TX startup time	Powermodes: STANDBY to FULLTX Notes 1, 2	40	40 + 1 x t _{bit}		μs
T _{rx_on}	RX startup time	Powermodes: STANDBY to FULLRX		190		μs
T _{rx_rssi}	RX startup time to valid RSSI	Powermodes: STANDBY to FULLRX		270 + 3 x t _{bit}		μs
T _{rx_data}	RX startup time to valid data at full sensitivity/selectivity	Modulation (G)FSK Notes 1, 2		190 + 9 x t _{bit}		μs
T _{rtx}	RX to TX switching	Powermodes: FULLRX to FULLTX		62		μs
T _{trrx}	TX to RX switching (to preamble start)	Powermodes: FULLTX to FULLRX		200		μs
T _{hop}	Frequency hop	Switch between frequency defined in register FREQA and FREQB		30		μs

1. t_{bit} depends on the datarate, e.g. for 10 kbps t_{bit} = 100 μs
2. In wire mode there is a processing delay of typically 6 x t_{bit} between antenna and DCLK/DATA pins

Table 15. SPI TIMING

Symbol	Description	Condition	Min	Typ	Max	Units
Tss	SEL falling edge to CLK rising edge		10			ns
Tsh	CLK falling edge to SEL rising edge		10			ns
Tssd	SEL falling edge to MISO driving		0		10	ns
Tssz	SEL rising edge to MISO high-Z		0		10	ns
Ts	MOSI setup time		10			ns
Th	MOSI hold time		10			ns
Tco	CLK falling edge to MISO output				10	ns
Tck	CLK period	Note 1	50			ns
Tcl	CLK low duration		40			ns
Tch	CLK high duration		40			ns

1. For SPI access during power-down mode the period should be relaxed to 100 ns

For a figure showing the SPI timing parameters see section: Serial Peripheral Interface (SPI).

Table 16. WIRE MODE INTERFACE TIMING

Symbol	Description	Condition	Min	Typ	Max	Units
Tdck	SEL falling edge to CLK rising edge	Depends on bit rate programming	1.6		10,000	μs
Tdcl	DCLK low duration		25		75	%
Tdch	DCLK high duration		25		75	%
Tds	DATA setup time relative to active DCLK edge		10			ns
Tdh	DATA hold time relative to active DCLK edge		10			ns
Tdco	DATA output change relative to active DCLK edge				10	ns

For a figure showing the wire mode interface timing parameters see section: Wire Mode Interface.

Table 17. GENERAL PURPOSE ADC (GPADC)

Symbol	Description	Condition	Min	Typ	Max	Units
Res	Nominal ADC resolution			10		bit
F _{conv}	Conversion rate		0.03		1	MS/s
DR	Dynamic range			60		dB
INL	Integral nonlinearity			± 1		LSB
DNL	Differential nonlinearity			± 1		LSB
Z _{in}	Input impedance			50		kΩ
V _{DC-IN}	Input DC level			0.8		V
V _{IN-DIFF}	Input signal range (differential)		-500		500	mV
V _{IN-SE}	Input signal range (single-ended, signal input at pin GPADC1, pin GPADC2 open)		300		1300	mV

CIRCUIT DESCRIPTION

The AX5043 is a true single chip ultra-low power narrow-band CMOS transceiver for use in licensed and unlicensed bands from 27 and 1050 MHz. The on-chip transceiver consists of a fully integrated RF front-end with modulator, and demodulator. Base band data processing is implemented in an advanced and flexible communication controller that enables user friendly communication via the SPI interface.

AX5043 can be operated from a 1.8 V to 3.6 V power supply over a temperature range of -40°C to 85°C . It consumes 7 – 48 mA for transmitting at 868 MHz carrier frequency, 4 – 51 mA for transmitting at 169 MHz depending on the output power. In receive operation AX 5043 consumes 9 – 11 mA at 868 MHz carrier frequency and 6.5 – 8.5 mA at 169 MHz.

The AX5043 features make it an ideal interface for integration into various battery powered solutions such as ticketing or as transceiver for telemetric applications e.g. in sensors. As primary application, the transceiver is intended for UHF radio equipment in accordance with the European Telecommunication Standard Institute (ETSI) specification EN 300 220-1 and the US Federal Communications Commission (FCC) standard Title 47 CFR Part 15 as well as Part 90. AX5043 is compliant with respective narrow-band regulations. Additionally AX5043 is suited for systems targeting compliance with Wireless M-Bus standard EN 13757-4:2005. Wireless M-Bus frame support (S, T, R) is built-in.

AX5043 supports any data rate from 0.1 kbps to 125 kbps for FSK, 4-FSK, GFSK, GMSK, MSK, ASK and PSK. To achieve optimum performance for specific data rates and modulation schemes several register settings to configure the AX5043 are necessary, for details see the AXSEM RadioLab Software which calculates the necessary register settings and the AX5043 Programming Manual.

The AX5043 can be operated in two fundamentally different modes.

In **frame mode** data is sent and received via the SPI port in frames. Pre- and post-ambles as well as checksums can be generated automatically. Interrupts control the data flow between a micro-controller and the AX5043.

In **wire mode** the IC behaves as an extension of any wire. The internal communication controller is disabled and the modem data is directly available on a dedicated pin (DATA). The bit clock is also output on a dedicated pin (DCLK). In this mode the user can connect the data pin to any port of a micro-controller or to a UART, but has to control coding, checksums, pre and post ambles. The user can choose between synchronous and asynchronous wire mode, asynchronous wire mode performs RS232 start bit recognition and re-synchronization for transmit.

Both modes can be used both for transmit and receive. In both cases the AX5043 behaves as a SPI slave interface. Configuration of the AX5043 is always done via the SPI interface.

The receiver and the transmitter support multi-channel operation for all data rates and modulation schemes.

Voltage Regulators

The AX5043 uses an on-chip voltage regulator system to create stable supply voltages for the internal circuitry from the primary supply VDD_IO. The I/O level of the digital pins is VDD_IO.

Pins VDD_ANA are supplied for external decoupling of the power supply used for the on-chip PA.

The voltage regulator system must be set into the appropriate state before receive or transmit operations can be initiated. This is handled automatically when programming the device modes via the PWRMODE register.

Register POWSTAT contains status bits that can be read to check if the regulated voltages are ready (bit SVIO) or if VDD_IO has dropped below the brown-out level of 1.3V (bit SSUM).

In power-down mode the core supply voltages for digital and analog functions are switched off to minimize leakage power. Most register contents are preserved but access to the FIFO is not possible and FIFO contents are lost. SPI access to registers is possible, but at lower speed.

In deep-sleep mode all supply voltages are switched off. All digital and analog functions are disabled. All register contents are lost. To leave deep-sleep mode the pin SEL has to be pulled low. This will initiate startup and reset of the AX5043. Then the MISO line should be polled, as it will be held low during initialization and will rise to high at the end of the initialization, when the chip becomes ready for operation.

Crystal Oscillator and TCXO Interface

The AX5043 is normally operated with an external TCXO, which is required by most narrow-band regulation with a tolerance of 0.5 ppm to 1.5 ppm depending on the regulation. The on-chip crystal oscillator allows the use of an inexpensive quartz crystal as the RF generation subsystem's timing reference when possible from a regulatory point of view.

A wide range of crystal frequencies can be handled by the crystal oscillator circuit. As the reference frequency impacts both the spectral performance of the transmitter as well as the current consumption of the receiver, the choice of reference frequency should be made according to the regulatory regime targeted by the application. For guidelines see the separate Application Notes for usage of AX5043 in compliance with various regulatory regimes.

The crystal or TCXO reference frequency should be chosen so that the RF carrier frequency is not an integer multiple of the crystal or TCXO frequency.

The oscillator circuit is enabled by programming the PWRMODE register. At power-up it is enabled.

AX5043

To adjust the circuit's characteristics to the quartz crystal being used, without using additional external components, the tuning capacitance of the crystal oscillator can be programmed. The transconductance of the oscillator is automatically regulated, to allow for fastest start-up times together with lowest power operation during steady-state oscillation.

The integrated programmable tuning capacitor bank makes it possible to connect the oscillator directly to pins CLK16N and CLK16P without the need for external capacitors. It is programmed using bits XTALCAP[5:0] in register XTALCAP.

To synchronize the receiver frequency to a carrier signal, the oscillator frequency could be tuned using the capacitor bank however, the recommended method to implement frequency synchronization is to make use of the high resolution RF frequency generation sub-system together with the Automatic Frequency Control, both are described further down.

Alternatively a single ended reference (TXCO, CXO) may be used. For detailed TCXO network recommendations depending on TCXO output swing refer to the AX5043 Application Note: Use with a TCXO Reference Clock.

Low Power Oscillator and Wake-on-Radio (WOR) Mode

The AX5043 features an internal lowest power fully integrated oscillator. In default mode the frequency of

oscillation is $640 \text{ Hz} \pm 1.5\%$, in fast mode it is $10.2 \text{ kHz} \pm 1.5\%$. These accuracies are reached after the internal hardware has been used to calibrate the low power oscillator versus the RF reference clock. This procedure can be run in the background during transmit or receive operations.

The low power oscillator makes a WOR mode with a power consumption of 500 nA possible.

If Wake on Radio Mode is enabled, the receiver wakes up periodically at a user selectable interval, and checks for a radio signal on the selected channel. If no signal is detected, the receiver shuts down again. If a radio signal is detected, and a valid packet is received, the microcontroller is alerted by asserting an interrupt.

The AX5043 can thus autonomously poll for radio signals, while the micro-controller can stay powered down, and only wakes up once a valid packet is received. This allows for very low average receiver power, at the expense of longer preambles at the transmitter.

GPIO Pins

Pins DATA, DCLK, SYSCLK, IRQ, ANTSEL, PWRAMP can be used as general purpose I/O pins by programming pin configuration registers PINFUNCSYSCLK, PINFUNCDCLK, PINFUNCDATA, PINFUNCIRQ, PINFUNCNANTSEL, PINFUNCPWRAMP. Pin input values can be read via register PINSTATE. Pull-ups are disabled if output data is programmed to the GPIO pin.

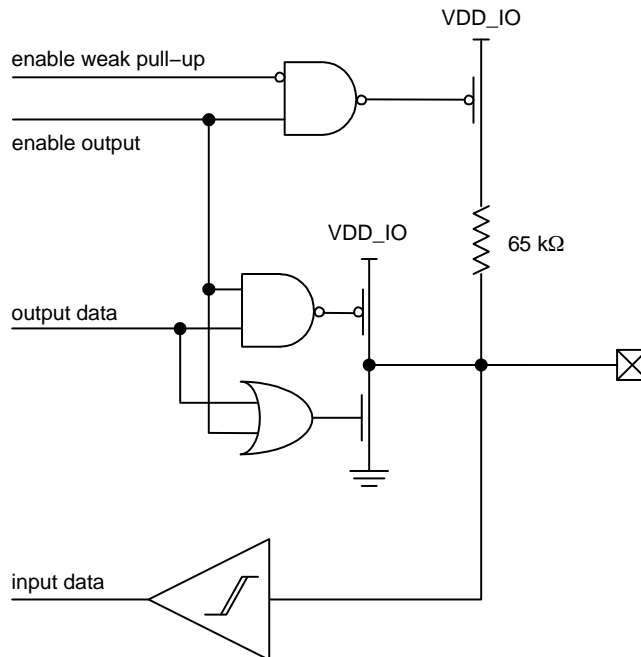

Figure 5. GPIO Pin

SYCLK Output

The SYCLK pin outputs either the reference clock signal divided by a programmable power of two or the low power oscillator clock. Division ratios from 1 to 1024 are possible. For divider ratios > 1 the duty cycle is 50%. Bits SYCLK[4:0] in the PINFUNCSYCLK register set the divider ratio. The SYCLK output can be disabled.

After power-up SYCLK outputs 1/16 of the crystal oscillator clock, making it possible to use this clock to boot a micro-controller.

Power-on-Reset (POR)

AX5043 has an integrated power-on-reset block. No external POR circuit is required.

After POR the AX5043 can be reset by first setting the SPI SEL pin to high for at least 100 ns, then setting followed by resetting the bit RST in the PWRMODE register.

After POR or reset all registers are set to their default values.

RF Frequency Generation Subsystem

The RF frequency generation subsystem consists of a fully integrated synthesizer, which multiplies the reference frequency from the crystal oscillator to get the desired RF frequency. The advanced architecture of the synthesizer enables frequency resolutions of 1 Hz, as well as fast settling times of 5 – 50 μ s depending on the settings (see section AC Characteristics). Fast settling times mean fast start-up and fast RX/TX switching, which enables low-power system design.

For receive operation the RF frequency is fed to the mixer, for transmit operation to the power-amplifier.

The frequency must be programmed to the desired carrier frequency.

The synthesizer loop bandwidth can be programmed, this serves three purposes:

1. Start-up time optimization, start-up is faster for higher synthesizer loop bandwidths
2. TX spectrum optimization, phase-noise at 300 kHz to 1 MHz distance from the carrier improves with lower synthesizer loop bandwidths
3. Adaptation of the bandwidth to the data-rate. For transmission of FSK and MSK it is required that the synthesizer bandwidth must be in the order of the data-rate.

VCO

An on-chip VCO converts the control voltage generated by the charge pump and loop filter into an output frequency. This frequency is used for transmit as well as for receive operation. The frequency can be programmed in 1 Hz steps in the FREQ registers. For operation in the 433 MHz band, the RFDIV bit in the PLLVCODIV register must be programmed.

The fully integrated VCO allows to operate the device in the frequency ranges 800 – 1050 MHz and 400 – 525 MHz.

The carrier frequency range can be extended to 54 – 525 MHz and 27 – 262 MHz by using an appropriate external inductor between device pins L1 and L2. The bit VCO2INT in the PLLVCODIV register must be set high to enter this mode.

It is also possible to use a fully external VCO by setting bits VCO2INT = 0 and VCOSEL = 1 in the PLLVCODIV register. A differential input at a frequency of double the desired RF frequency must be input at device pins L1 and L2. The control voltage for the VCO can be output at device pin FILT when using external filter mode. The voltage range of this output pin is 0 – 1.8 V.

This mode of operation is recommended for special applications where the phase noise requirements are not met when using the fully internal VCO or the internal VCO with external inductor.

VCO Auto-Ranging

The AX5043 has an integrated auto-ranging function, which allows to set the correct VCO range for specific frequency generation subsystem settings automatically. Typically it has to be executed after power-up. The function is initiated by setting the RNG_START bit in the PLLRANGINGA or PLLRANGINGB register. The bit is readable and a 0 indicates the end of the ranging process. Setting RNG_START in the PLLRANGINGA register ranges the frequency in FREQA, while setting RNG_START in the PLLRANGINGB register ranges the frequency in FREQB. The RNGERR bit indicates the correct execution of the auto-ranging.

VCO auto-ranging works with the fully integrated VCO and with the internal VCO with external inductor.

Loop Filter and Charge Pump

The AX5043 internal loop filter configuration together with the charge pump current sets the synthesizer loop bandwidth. The internal loop-filter has three configurations that can be programmed via the register bits FLT[1:0] in registers PLLLOOP or PLLLOOPBOOST the charge pump current can be programmed using register bits PLLCPI[7:0] in registers PLLCPI or PLLCPIBOOST. Synthesizer bandwidths are typically 50 – 500 kHz depending on the PLLLOOP or PLLLOOPBOOST settings, for details see the section: AC Characteristics.

The AX5043 can be setup in such a way that when the synthesizer is started, the settings in the registers PLLLOOPBOOST and PLLCPIBOOST are applied first for a programmable duration before reverting to the settings in PLLLOOP and PLLCPI. This feature enables automated fastest start-up.

Setting bits FLT[1:0] = 00 bypasses the internal loop filter and the VCO control voltage is output to an external loop filter at pin FILT. This mode of operation is recommended for achieving lower bandwidths than with the internal loop filter and for usage with a fully external VCO.

Table 18. RF FREQUENCY GENERATION REGISTERS

Register	Bits	Purpose
PLLLOOP PLLLOOPBOOST	FLT[1:0]	Synthesizer loop filter bandwidth and selection of external loop filter, recommended usage is to increase the bandwidth for faster settling time, bandwidth increases of factor 2 and 5 are possible.
PLLCPI PLLCPIBOOST		Synthesizer charge pump current, recommended usage is to decrease the bandwidth (and improve the phase-noise) for low data-rate transmissions.
PLLVCODIV	REFDIV	Sets the synthesizer reference divider ratio.
	RFDIV	Sets the synthesizer output divider ratio.
	VCOSEL	Selects either the internal or the external VCO
	VCO2INT	Selects either the internal VCO inductor or an external inductor between pins L1 and L2
FREQA, FREQB		Programming of the carrier frequency
PLLRANGINGA, PLLRANGINGB		Initiate VCO auto-ranging and check results

RF Input and Output Stage (ANTP/ANTN/ANTP1)

The AX5043 has two main antenna interface modes:

- Both RX and TX use differential pins ANTP and ANTN. RX/TX switching is handled internally. This mode is recommended for highest output powers, highest sensitivities and for direct connection to dipole antennas. Also see Figure 13.
- RX uses the differential antenna pins ANTP and ANTN. TX uses the single ended antenna pin ANTP1. RX/TX switching is handled externally. This can be done either with an external RX/TX switch or with a direct tie configuration. This mode is recommended for low output powers at high efficiency (Figure 16) and for usage with external power amplifiers (Figure 15).

Pin PWRAMP can be used to control an external RX/TX switch when operating the device together with an external PA (Figure 15). Pin ANTSEL can be used to control an external antenna switch when receiving with two antennas (Figure 17).

When antenna diversity is enabled, the radio controller will, when not in the middle of receiving a packet, periodically probe both antennas and select the antenna with the highest signal strength. The radio controller can be instructed to periodically write both RSSI values into the FIFO. Antenna diversity mode is fully automatic.

LNA

The LNA amplifies the differential RF signal from the antenna and buffers it to drive the I/Q mixer. An external matching network is used to adapt the antenna impedance to the IC impedance. A DC feed to GND must be provided at the antenna pins. For recommendations see section: Application Information.

PA

In TX mode the PA drives the signal generated by the frequency generation subsystem out to either the differential antenna terminals or to the single ended antenna pin. The antenna terminals are chosen via the bits TXDIFF and TXSE in register MODECFGA.

The output power of the PA is programmed via the register TXPWRCOEFFB.

The PA can be digitally pre-distorted for high linearity.

The output amplitude can be shaped (raised cosine), this mode is selected with bit AMPLSHAPE in register MODECFGA. PA ramping is programmable in increments of the bit time and can be set to 1 – 8 bit times via bits SLOWRAMP in register MODECFGA.

Output power as well as harmonic content will depend on the external impedance seen by the PA, recommendations are given in the section: Application Information.

Digital IF Channel Filter and Demodulator

The digital IF channel filter and the demodulator extract the data bit-stream from the incoming IF signal. They must be programmed to match the modulation scheme as well as the data-rate. Inaccurate programming will lead to loss of sensitivity.

The channel filter offers bandwidths of 995 Hz up to 221 kHz.

The AXSEM RadioLab Software calculates the necessary register settings for optimal performance and details can be found in the AX5043 Programming Manual. An overview of the registers involved is given in the following table as reference. The register setups typically must be done once at power-up of the device.

Table 19. CHANNEL FILTER AND DEMODULATOR REGISTERS

Register	Remarks
DECIMATION	This register programs the bandwidth of the digital channel filter.
RXDATARATE2... RXDATARATE0	These registers specify the receiver bit rate, relative to the channel filter bandwidth.
MAXDROFFSET2... MAXDROFFSET0	These registers specify the maximum possible data rate offset.
MAXRFOFFSET2... MAXRFOFFSET0	These registers specify the maximum possible RF frequency offset.
TIMEGAIN, DRGAIN	These registers specify the aggressiveness of the receiver bit timing recovery. More aggressive settings allow the receiver to synchronize with shorter preambles, at the expense of more timing jitter and thus a higher bit error rate at a given signal-to-noise ratio.
MODULATION	This register selects the modulation to be used by the transmitter and the receiver, i.e. whether ASK, FSK should be used.
PHASEGAIN, FREQGAINA, FREQGAINB, FREQGAINC, FREQGAIND, AMPLGAIN	These registers control the bandwidth of the phase, frequency offset and amplitude tracking loops.
AGCGAIN	This register controls the AGC (automatic gain control) loop slopes, and thus the speed of gain adjustments. The faster the bit-rate, the faster the AGC loop should be.
TXRATE	These registers control the bit rate of the transmitter.
FSKDEV	These registers control the frequency deviation of the transmitter in FSK mode. The receiver does not explicitly need to know the frequency deviation, only the channel filter bandwidth has to be set wide enough for the complete modulation to pass.

Encoder

The encoder is located between the Framing Unit, the Demodulator and the Modulator. It can optionally transform the bit-stream in the following ways:

- It can invert the bit stream.
- It can perform differential encoding. This means that a zero is transmitted as no change in the level, and a one is transmitted as a change in the level.
- It can perform Manchester encoding. Manchester encoding ensures that the modulation has no DC content and enough transitions (changes from 0 to 1 and from 1 to 0) for the demodulator bit timing recovery to function correctly, but does so at a doubling of the data rate.
- It can perform spectral shaping (also known as whitening). Spectral shaping removes DC content of the bit stream, ensures transitions for the demodulator bit timing recovery, and makes sure that the transmitted spectrum does not have discrete lines even if the transmitted data is cyclic. It does so without adding additional bits, i.e. without changing the data rate. Spectral Shaping uses a self synchronizing feedback shift register.

The encoder is programmed using the register ENCODING, details and recommendations on usage are given in the AX5043 Programming Manual.

Framing and FIFO

Most radio systems today group data into packets. The framing unit is responsible for converting these packets into

a bit-stream suitable for the modulator, and to extract packets from the continuous bit-stream arriving from the demodulator.

The Framing unit supports two different modes:

- Packet modes
- Raw modes

The micro-controller communicates with the framing unit through a 256 byte FIFO. Data in the FIFO is organized in Chunks. The chunk header encodes the length and what data is contained in the payload. Chunks may contain packet data, but also RSSI, Frequency offset, Timestamps, etc.

The AX5043 contains one FIFO. Its direction is switched depending on whether transmit or receive mode is selected.

The FIFO can be operated in polled or interrupt driven modes. In polled mode, the microcontroller must periodically read the FIFO status register or the FIFO count register to determine whether the FIFO needs servicing.

In interrupt mode EMPTY, NOT EMPTY, FULL, NOT FULL and programmable level interrupts are provided. The AX5043 signals interrupts by asserting (driving high) its IRQ line. The interrupt line is level triggered, active high. Interrupts are acknowledged by removing the cause for the interrupt, i.e. by emptying or filling the FIFO.

Basic FIFO status (EMPTY, FULL, Overrun, Underrun, FIFO fill level above threshold, FIFO free space above threshold) are also provided during each SPI access on MISO while the micro-controller shifts out the register address on MOSI. See the SPI interface section for details. This feature significantly reduces the number of SPI accesses necessary during transmit and receive.

AX5043

Packet Modes

The AX5043 offers different packet modes. For arbitrary packet sizes HDLC is recommended since the flag and bit-stuffing mechanism. The AX5043 also offers packet modes with fixed packet length with a byte indicating the length of the packet.

In packet modes a CRC can be computed automatically.

HDLC Mode is the main framing mode of the AX5043. In this mode, the AX5043 performs automatic packet

delimiting, and optional packet correctness check by inserting and checking a cyclic redundancy check (CRC) field.

NOTE: HDLC mode follows High-Level Data Link Control (HDLC, ISO 13239) protocol.

The packet structure is given in the following table.

Table 20. HDLC PACKET STRUCTURE

Flag	Address	Control	Information	FCS	(Optional Flag)
8 bit	8 bit	8 or 16 bit	Variable length, 0 or more bits in multiples of 8	16 / 32 bit	8 bit

HDLC packets are delimited with flag sequences of content 0x7E.

In AX5043 the meaning of address and control is user defined. The Frame Check Sequence (FCS) can be programmed to be CRC-CCITT, CRC-16 or CRC-32.

The receiver checks the CRC, the result can be retrieved from the FIFO, the CRC is appended to the received data.

In Wireless M-Bus Mode, the packet structure is given in the following table.

NOTE: Wireless M-Bus mode follows EN13757-4

Table 21. WIRELESS M-BUS PACKET STRUCTURE

Preamble	L	C	M	A	FCS	Optional Data Block (optionally repeated with FCS)	FCS
variable	8 bit	8 bit	16 bit	48 bit	16 bit	8 – 96 bit	16 bit

For details on implementing a HDLC communication as well as Wireless M-Bus please use the AXSEM RadioLab software and see the AX5043 Programming Manual.

Raw Modes

In Raw mode, the AX5043 does not perform any packet delimiting or byte synchronization. It simply serializes transmit bytes and de-serializes the received bit-stream and groups it into bytes. This mode is ideal for implementing legacy protocols in software.

Raw mode with preamble match is similar to raw mode. In this mode, however, the receiver does not receive anything until it detects a user programmable bit pattern (called the preamble) in the receive bit-stream. When it detects the preamble, it aligns the de-serialization to it.

The preamble can be between 4 and 32 bits long.

RX AGC and RSSI

AX5043 features three receiver signal strength indicators (RSSI):

1. RSSI before the digital IF channel filter.

The gain of the receiver is adjusted in order to keep the analog IF filter output level inside the working range of the ADC and demodulator. The register AGCCOUNTER contains the current

value of the AGC and can be used as an RSSI. The step size of this RSSI is 0.625 dB. The value can be used as soon as the RF frequency generation sub-system has been programmed.

2. RSSI behind the digital IF channel filter.

The register RSSI contains the current value of the RSSI behind the digital IF channel filter. The step size of this RSSI is 1 dB.

3. RSSI behind the digital IF channel filter high accuracy.

The demodulator also provides amplitude information in the TRK_AMPLITUDE register. By combining both the AGCCOUNTER and the TRK_AMPLITUDE registers, a high resolution (better than 0.1 dB) RSSI value can be computed at the expense of a few arithmetic operations on the micro-controller. The AXSEM RadioLab Software calculates the necessary register settings for best performance and details can be found in the AX5043 Programming Manual.

Modulator

Depending on the transmitter settings the modulator generates various inputs for the PA:

Table 22. MODULATIONS

Modulation	Bit = 0	Bit = 1	Main Lobe Bandwidth	Max. Bitrate
ASK	PA off	PA on	BW = BITRATE	125 kBit/s
FSK/MSK/GFSK/GMSK	$\Delta f = -f_{\text{deviation}}$	$\Delta f = +f_{\text{deviation}}$	$BW = (1 + h) \cdot \text{BITRATE}$	125 kBit/s
PSK	$\Delta\Phi = 0^\circ$	$\Delta\Phi = 180^\circ$	BW = BITRATE	125 kBit/s

h = modulation index. It is the ratio of the deviation compared to the bit-rate; $f_{\text{deviation}} = 0.5 \cdot h \cdot \text{BITRATE}$, AX5043 can demodulate signals with $h < 32$.

ASK = amplitude shift keying

FSK = frequency shift keying

MSK= minimum shift keying; MSK is a special case of FSK, where $h = 0.5$, and therefore

$f_{\text{deviation}} = 0.25 \cdot \text{BITRATE}$; the advantage of MSK over FSK is that it can be demodulated more robustly.

PSK = phase shift keying

All modulation schemes, except 4-FSK, are binary.

Amplitude can be shaped using a raised cosine waveform. Amplitude shaping will also be performed for constant amplitude modulation ((G)FSK, (G)MSK) for ramping up and down the PA. Amplitude shaping should always be enabled.

Frequency shaping can either be hard (FSK, MSK), or Gaussian (GMSK, GFSK), with selectable $BT = 0.3$ or $BT = 0.5$.

Table 23. 4-FSK MODULATION

Modulation	DiBit = 00	DiBit = 01	DiBit = 11	DiBit = 10	Main Lobe Bandwidth	Max. Bitrate
4-FSK	$\Delta f = -3f_{\text{deviation}}$	$\Delta f = -f_{\text{deviation}}$	$\Delta f = +f_{\text{deviation}}$	$\Delta f = +3f_{\text{deviation}}$	$BW = (1 + 3h) \cdot \text{BITRATE}$	125 kBit/s

4-FSK Frequency shaping is always hard.

$$\Delta f = \frac{\text{TRKRFFREQ}}{2^{24}} f_{\text{XTAL}}$$

Automatic Frequency Control (AFC)

The AX5043 features an automatic frequency tracking loop which is capable of tracking the transmitter frequency within the RX filter band width. On top of that the AX5043 has a frequency tracking register TRKRFFREQ to synchronize the receiver frequency to a carrier signal. For AFC adjustment, the frequency offset can be computed with the following formula:

The pull-in range of the AFC can be programmed with the MAXRFOFFSET Registers.

PWRMODE Register

The PWRMODE register controls, which parts of the chip are operating.

Table 24. PWRMODE REGISTER

PWRMODE Register	Name	Description
0000	POWERDOWN	All digital and analog functions, except the register file, are disabled. The core supply voltages are switched off to conserve leakage power. Register contents are preserved and accessible registers via SPI, but at a slower speed. Access to the FIFO is not possible and the contents are not preserved. POWERDOWN mode is only entered once the FIFO is empty.
0001	DEEPSLEEP	AX5043 is fully turned off. All digital and analog functions are disabled. All register contents are lost. To leave DEEPSLEEP mode the pin SEL has to be pulled low. This will initiate startup and reset of the AX5043. Then the MISO line should be polled, as it will be held low during initialization and will rise to high at the end of the initialization, when the chip becomes ready for operation.
0101	STANDBY	The crystal oscillator and the reference are powered on; receiver and transmitter are off. Register contents are preserved and accessible registers via SPI. Access to the FIFO is not possible and the contents are not preserved. STANDBY is only entered once the FIFO is empty.
0110	FIFO	The reference is powered on. Register contents are preserved and accessible registers via SPI. Access to the FIFO is possible and the contents are preserved.
1000	SYNTHRX	The synthesizer is running on the receive frequency. Transmitter and receiver are still off. This mode is used to let the synthesizer settle on the correct frequency for receive.
1001	FULLRX	Synthesizer and receiver are running.

Table 24. PWRMODE REGISTER

PWRMODE Register	Name	Description
1011	WOR	Receiver wakeup-on-radio mode. The mode the same as POWERDOWN, but the 640 Hz internal low power oscillator is running.
1100	SYNTHTX	The synthesizer is running on the transmit frequency. Transmitter and receiver are still off. This mode is used to let the synthesizer settle on the correct frequency for transmit.
1101	FULLTX	Synthesizer and transmitter are running. Do not switch into this mode before the synthesizer has completely settled on the transmit frequency (in SYNTHTX mode), otherwise spurious spectral transmissions will occur.

Table 25. A TYPICAL PWRMODE SEQUENCE FOR A TRANSMIT SESSION

Step	PWRMODE	Remarks
1	POWERDOWN	
2	STANDBY	The settling time is dominated by the crystal used, typical value 3ms.
3	FULLTX	Data transmission
4	POWERDOWN	

Table 26. A TYPICAL PWRMODE SEQUENCE FOR A RECEIVE SESSION

Step	PWRMODE [3:0]	Remarks
1	POWERDOWN	
2	STANDBY	The settling time is dominated by the crystal used, typical value 3ms.
3	FULLRX	Data reception
4	POWERDOWN	

Serial Peripheral Interface

The AX5043 can be programmed via a four wire serial interface according SPI using the pins CLK, MOSI, MISO and SEL. Registers for setting up the AX5043 are programmed via the serial peripheral interface in all device modes.

When the interface signal SEL is pulled low, a configuration data stream is expected on the input signal pin MOSI, which is interpreted as D0...Dx, A0...Ax, R_N/W. Data read from the interface appears on MISO.

Figure 6 shows a write/read access to the interface. The data stream is built of an address byte including read/write information and a data byte. Depending on the R_N/W bit and address bits A[6..0], data D[7..0] can be written via MOSI or read at the pin MISO. R_N/W = 0 means read mode, R_N/W = 1 means write mode.

Most registers are 8 bits wide and accessed using the waveforms as detailed in Figure 7. The most important

registers are at the beginning of the address space, i.e. at addresses less than 0x70. These registers can be accessed more efficiently using the short address form, which is detailed in Figure 6.

Some registers are longer than 8 bits. These registers can be accessed more quickly than by reading and writing individual 8 bit parts. This is illustrated in Figure 8. Accesses are not limited by 16 bits either, reading and writing data bytes can be continued as long as desired. After each byte, the address counter is incremented by one. Also, this access form works with long addresses.

During the address phase of the access, the AX5043 outputs the most important status bits. This feature is designed to speed up the software decision on what to do in an interrupt handler.

The status bits contain the following information:

Table 27. SPI STATUS BITS

SPI Bit Cell	Status	Meaning / Register Bit
0	-	1 (when transitioning out of deep sleep mode, this bit transitions from 0 → 1 when the power becomes ready)
1	S14	PLL LOCK
2	S13	FIFO OVER

Table 27. SPI STATUS BITS

SPI Bit Cell	Status	Meaning / Register Bit
3	S12	FIFO UNDER
4	S11	THRESHOLD FREE (FIFOFREE > FIFOTHRESH)
5	S10	THRESHOLD COUNT (FIFOCOUNT > FIFOTHRESH)
6	S9	FIFO FULL
7	S8	FIFO EMPTY
8	S7	PWRGOOD (not BROWNOUT)
9	S6	PWR INTERRUPT PENDING
10	S5	RADIO EVENT PENDING
11	S4	XTAL OSCILLATOR RUNNING
12	S3	WAKEUP INTERRUPT PENDING
13	S2	LPOSC INTERRUPT PENDING
14	S1	GPADC INTERRUPT PENDING
15	S0	internal

NOTE: Bit cells 8–15 (S7...S0) are only available in two address byte SPI access formats.

SPI Timing

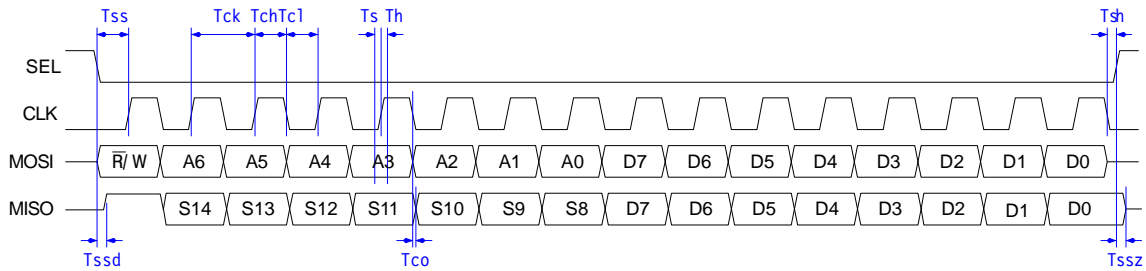

Figure 6. SPI 8 Bit Read/Write Access with Timing

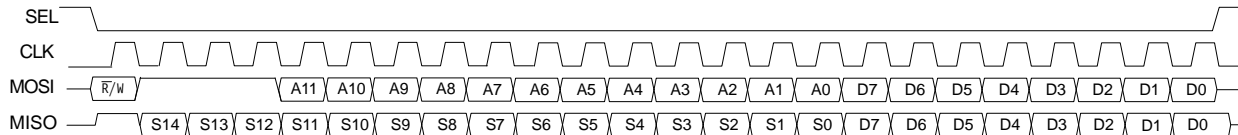

Figure 7. SPI 8 Bit Long Address Read/Write Access

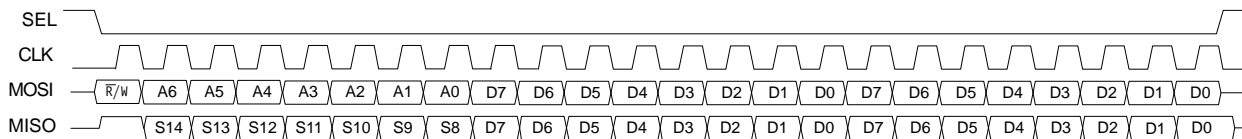

Figure 8. SPI 16 Bit Long Read/Write Access

Wire Mode Interface

In wire mode the transmitted or received data are transferred from and to the AX5043 using the pins DATA and DCLK. DATA is an input when transmitting and an output when receiving.

The direction can be chosen by programming the PWRMODE register.

Wire mode offers two variants: synchronous or asynchronous.

In synchronous wire mode the, the AX5043 always drives DCLK. Transmit data must be applied to DATA synchronously to DCLK, and receive data must be sampled synchronously to DCLK. Timing is given in Figure 9. In asynchronous wire mode, a low voltage RS232 type UART can be connected to DATA. DCLK is optional in this mode. The UART must be programmed to send two stop bits, but must be able to accept only one stop bit. Both the UART data rate and the AX5043 transmit and receive bit rate must match. The AX5043 synchronizes the RS232 signal to its internal transmission clock, by inserting or deleting a stop bit.

Wiremode is also available in 4-FSK mode. The two bits that encode one symbol are serialized on the DATA pin. The PWRAMP pin can be used as a synchronisation pin to allow symbol (dibit) boundaries to be reconstructed. Gray coding is used to reduce the number of bit errors in case of a wrong decision. The AXSEM RadioLab software calculates the necessary register settings for best performance and details can be found in the AX5043 Programming Manual.

Registers for setting up the AX5043 are programmed via the serial peripheral interface (SPI).

Wire Mode Timing

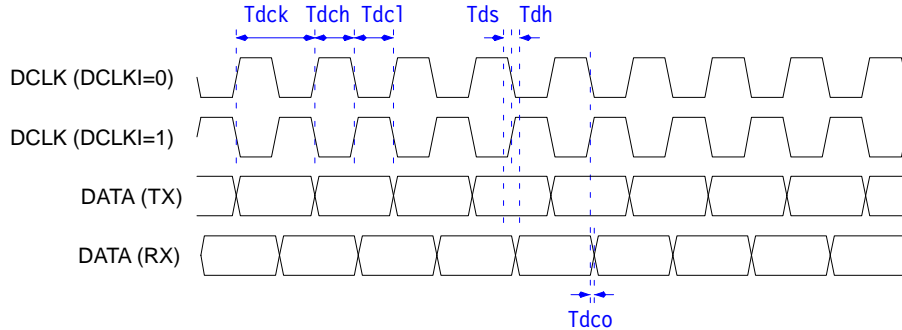

Figure 9. Wire Mode Interface Timing

General Purpose ADC (GPADC)

The AX5043 features a general purpose ADC. The ADC input pins are GPADC1 and GPADC2. The ADC converts the voltage difference applied between pins GPADC1 and GPADC2. If pin GPADC2 is left open, the ADC converts the difference between an internally generated value of 800 mV and the voltage applied at pin GPADC1.

The GPADC can only be used if the receiver is disabled. To enable the GPADC write 1 to the GPADC13 bit in the GPADCCTRL register. To start a single conversion, write 1 to the BUSY bit in the GPADCCTRL register. Then wait for the BUSY bit to clear, or the GPADC Interrupt to be asserted.

The GPADC Interrupt is cleared by reading the result register GPADC13VALUE.

If continuous sampling is desired, set the CONT bit in register GPADCCTRL. The desired sampling rate can be specified in the GPADCPERIOD register.

ΣΔ DAC

One digital Pin (ANTSEL or PWRAMP) may be used as a ΣΔ Digital-to-Analog Converter. A simple RC lowpass filter is needed to smooth the output. The DAC may be used to output RSSI, many demodulator variables, or a constant value under software control.

REGISTER BANK DESCRIPTION

This section describes the bits of the register bank as reference. The registers are grouped by functional block to facilitate programming. The AXSEM RadioLab software calculates the necessary register settings for best performance and details can be found in the AX5043 Programming Manual.

An R in the retention column means that this register's contents are not lost during power-down mode.

No checks are made whether the programmed combination of bits makes sense! Bit 0 is always the LSB.

NOTES: Whole registers or register bits marked as reserved should be kept at their default values.

All addresses not documented here must not be accessed, neither in reading nor in writing.

The retention column indicates if the register contents are preserved in power-down mode.

Table 28. CONTROL REGISTER MAP

Add	Name	Dir	Ret	Reset	Bit								Description
					7	6	5	4	3	2	1	0	
Revision & Interface Probing													
000	REVISION	R	R	01010001	SILICONREV(7:0)								Silicon Revision
001	SCRATCH	RW	R	11000101	SCRATCH(7:0)								Scratch Register
Operating Mode													
002	PWRMODE	RW	R	011-0000	RST	XOEN	REFEN	WDS	PWRMODE(3:0)			Power Mode	
Voltage Regulator													
003	POWSTAT	R	R	-----	SSUM	SREF	SVREF	SVANA	SVMODEM	SBEVANA	SBEVMODEM	SVIO	Power Management Status
004	POWSTICKYST AT	R	R	-----	SSSUM	SREF	SSVREF	SSVANA	SSVMODEM	SSBEVANA	SSBEVMODEM	SSVIO	Power Management Sticky Status
005	POWIRQMASK	RW	R	00000000	MPWR GOOD	MSREF	MSVREF	MS VANA	MS VMODEM	MSBE VANA	MSBE VMODEM	MSVIO	Power Management Interrupt Mask
Interrupt Control													
006	IRQMASK1	RW	R	---00000	-	-	IRQMASK(13:8)					IRQ Mask	
007	IRQMASK0	RW	R	00000000	IRQMASK(7:0)								IRQ Mask
008	RADIOEVENTM ASK1	RW	R	-----0	-	-	-	-	-	-	-	RADIO EVENT MASK(8)	Radio Event Mask
009	RADIOEVENTM ASK0	RW	R	00000000	RADIO EVENT MASK(7:0)								Radio Event Mask
00A	IRQINVERSION 1	RW	R	---00000	-	-	IRQINVERSION(13:8)					IRQ Inversion	
00B	IRQINVERSION 0	RW	R	00000000	IRQINVERSION(7:0)								IRQ Inversion
00C	IRQREQUEST1	R	R	-----	-	-	IRQREQUEST(13:8)					IRQ Request	
00D	IRQREQUEST0	R	R	-----	IRQREQUEST(7:0)								IRQ Request
00E	RADIOEVENTR EQ1	R		-----	-	-	-	-	-	-	-	RADIO EVENT REQ(8)	Radio Event Request
00F	RADIOEVENTR EQ0	R		-----	RADIO EVENT REQ(7:0)								Radio Event Request
Modulation & Framing													
010	MODULATION	RW	R	---01000	-	-	-	RX HALF SPEED	MODULATION(3:0)				Modulation
011	ENCODING	RW	R	---00010	-	-	-	ENC NOSYNC	ENC MANCH	ENC SCRAM	ENC DIFF	ENC INV	Encoder/Decoder Settings
012	FRAMING	RW	R	-0000000	FRMRX	CRCMODE(2:0)			FRMMODE(2:0)			FABORT	Framing settings
014	CRCINIT3	RW	R	11111111	CRCINIT(31:24)								CRC Initialisation Data
015	CRCINIT2	RW	R	11111111	CRCINIT(23:16)								CRC Initialisation Data
016	CRCINIT1	RW	R	11111111	CRCINIT(15:8)								CRC Initialisation Data
017	CRCINIT0	RW	R	11111111	CRCINIT(7:0)								CRC Initialisation Data
Forward Error Correction													
018	FEC	RW	R	00000000	SHORT MEM	RSTVI TERBI	FEC NEG	FEC POS	FECINPSHIFT(2:0)			FEC ENA	FEC (Viterbi) Configuration
019	FECSYNC	RW	R	01100010	FECSYNC(7:0)								Interleaver Synchronisation Threshold
01A	FECSTATUS	R	R	-----	FEC INV	MAXMETRIC(6:0)						FEC Status	

Table 28. CONTROL REGISTER MAP

Add	Name	Dir	Ret	Reset	Bit								Description	
					7	6	5	4	3	2	1	0		
Status														
01C	RADIOSTATE	R	-	0000	-	-	-	-	-	-	-	-	RADIOSTATE(3:0)	Radio Controller State
01D	XTALSTATUS	R	R	-	-	-	-	-	-	-	-	-	XTAL RUN	Crystal Oscillator Status
Pin Configuration														
020	PINSTATE	R	R	-	-	-	PS PWR AMP	PS ANT SEL	PS IRQ	PS DATA	PS DCLK	PS SYS CLK	-	Pinstate
021	PINFUNCSYCLK	RW	R	0—01000	PU SYSCLK	-	-	-	-	-	-	-	PFSYSCLK(4:0)	SYSCLK Pin Function
022	PINFUNCDCLK	RW	R	00—100	PU DCLK	PI DCLK	-	-	-	-	-	-	PFDCCLK(2:0)	DCLK Pin Function
023	PINFUNCDATA	RW	R	10—111	PU DATA	PI DATA	-	-	-	-	-	-	PFDATA(2:0)	DATA Pin Function
024	PINFUNCIRQ	RW	R	00—011	PU IRQ	PI IRQ	-	-	-	-	-	-	PFIRQ(2:0)	IRQ Pin Function
025	PINFUNCANTSEL	RW	R	00—110	PU ANTSEL	PI ANTSEL	-	-	-	-	-	-	PFANTSEL(2:0)	ANTSEL Pin Function
026	PINFUNCPWRAMP	RW	R	00—0110	PU PWRAMP	PI PWRAMP	-	-	-	-	-	-	PFWRAMP(3:0)	PWRAMP Pin Function
027	PWRAMP	RW	R	-—0	-	-	-	-	-	-	-	-	PWRAMP	PWRAMP Control
FIFO														
028	FIFOSTAT	R	R	0—	FIFO AUTO COMMIT	-	FIFO FREE THR	FIFO CNT THR	FIFO OVER	FIFO UNDER	FIFO FULL	FIFO EMPTY	-	FIFO Control
		W	R	-	-	-	-	-	-	-	-	-	FIFOCMD(5:0)	
029	FIFODATA	RW		-	FIFODATA(7:0)	-	-	-	-	-	-	-	-	FIFO Data
02A	FIFOCOUNT1	R	R	-—0	-	-	-	-	-	-	-	-	FIFO COUNT(8)	Number of Words currently in FIFO
02B	FIFOCOUNT0	R	R	00000000	FIFOCOUNT(7:0)	-	-	-	-	-	-	-	-	Number of Words currently in FIFO
02C	FIFOFREE1	R	R	-—1	-	-	-	-	-	-	-	-	FIFO FREE(8)	Number of Words that can be written to FIFO
02D	FIFOFREE0	R	R	00000000	FIFOFREE(7:0)	-	-	-	-	-	-	-	-	Number of Words that can be written to FIFO
02E	FIFOTHRESH1	RW	R	-—0	-	-	-	-	-	-	-	-	FIFO THRESH(8)	FIFO Threshold
02F	FIFOTHRESH0	RW	R	00000000	FIFOTHRESH(7:0)	-	-	-	-	-	-	-	-	FIFO Threshold
Synthesizer														
030	PLLLOOP	RW	R	0—1001	FREQB	-	-	-	DIRECT	FILT EN	FLT(1:0)	-	PLL Loop Filter Settings	
031	PLLCPI	RW	R	00001000	PLLCPI	-	-	-	-	-	-	-	PLL Charge Pump Current (Boosted)	
032	PLLVCODIV	RW	R	-00—000	-	VCOI MAN	VCO2INT	VCOSEL	-	RFDIV	REFDIV(1:0)	-	PLL Divider Settings	
033	PLLRANGINGA	RW	R	00001000	STICKY LOCK	PLL LOCK	RNGERR	RNG START	VCORA(3:0)	-	-	-	PLL Autoranging	
034	FREQA3	RW	R	00111001	FREQA(31:24)	-	-	-	-	-	-	-	Synthesizer Frequency	
035	FREQA2	RW	R	00110100	FREQA(23:16)	-	-	-	-	-	-	-	Synthesizer Frequency	
036	FREQA1	RW	R	11001100	FREQA(15:8)	-	-	-	-	-	-	-	Synthesizer Frequency	
037	FREQA0	RW	R	11001101	FREQA(7:0)	-	-	-	-	-	-	-	Synthesizer Frequency	
038	PLLLOOPBOOST	RW	R	0—1011	FREQB	-	-	-	DIRECT	FILT EN	FLT(1:0)	-	PLL Loop Filter Settings (Boosted)	
039	PLLCPIBOOST	RW	R	11001000	PLLCPI	-	-	-	-	-	-	-	PLL Charge Pump Current	
03B	PLLRANGINGB	RW	R	00001000	STICKY LOCK	PLL LOCK	RNGERR	RNG START	VCORB(3:0)	-	-	-	PLL Autoranging	
03C	FREQB3	RW	R	00111001	FREQB(31:24)	-	-	-	-	-	-	-	Synthesizer Frequency	
03D	FREQB2	RW	R	00110100	FREQB(23:16)	-	-	-	-	-	-	-	Synthesizer Frequency	
03E	FREQB1	RW	R	11001100	FREQB(15:8)	-	-	-	-	-	-	-	Synthesizer Frequency	
03F	FREQB0	RW	R	11001101	FREQB(7:0)	-	-	-	-	-	-	-	Synthesizer Frequency	
Signal Strength														
040	RSSI	R	R	-	RSSI(7:0)	-	-	-	-	-	-	-	Received Signal Strength Indicator	
041	BGNDRSSI	RW	R	00000000	BGNDRSSI(7:0)	-	-	-	-	-	-	-	Background RSSI	
042	DIVERSITY	RW	R	-—00	-	-	-	-	-	-	-	ANT SEL	DIV ENA	Antenna Diversity Configuration

Table 28. CONTROL REGISTER MAP

Add	Name	Dir	Ret	Reset	Bit								Description
					7	6	5	4	3	2	1	0	
043	AGCCOUNTER	RW	R	-----	AGCCOUNTER(7:0)								AGC Current Value
Receiver Tracking													
045	TRKDATARATE2	R	R	-----	TRKDATARATE(23:16)								Datarate Tracking
046	TRKDATARATE1	R	R	-----	TRKDATARATE(15:8)								Datarate Tracking
047	TRKDATARATE0	R	R	-----	TRKDATARATE(7:0)								Datarate Tracking
048	TRKAMPL1	R	R	-----	TRKAMPL(15:8)								Amplitude Tracking
049	TRKAMPL0	R	R	-----	TRKAMPL(7:0)								Amplitude Tracking
04A	TRKPHASE1	R	R	-----	-	-	-	-	TRKPHASE(11:8)				Phase Tracking
04B	TRKPHASE0	R	R	-----	TRKPHASE(7:0)								Phase Tracking
04D	TRKRFFREQ2	RW	R	-----	-	-	-	-	TRRKFREQ(19:16)				RF Frequency Tracking
04E	TRKRFFREQ1	RW	R	-----	TRRKFREQ(15:8)								RF Frequency Tracking
04F	TRKRFFREQ0	RW	R	-----	TRRKFREQ(7:0)								RF Frequency Tracking
050	TRKFREQ1	RW	R	-----	TRKFREQ(15:8)								Frequency Tracking
051	TRKFREQ0	RW	R	-----	TRKFREQ(7:0)								Frequency Tracking
052	TRKFSKDEMO D1	R	R	-----	-	-	TRKFSKDEMOD(13:8)					FSK Demodulator Tracking	
053	TRKFSKDEMO D0	R	R	-----	TRKFSKDEMOD(7:0)								FSK Demodulator Tracking
054	TRKAFSKDEM OD1	R	R	-----	TRKAFSKDEMOD(15:8)								AFSK Demodulator Tracking
055	TRKAFSKDEM OD0	R	R	-----	TRKAFSKDEMOD(7:0)								AFSK Demodulator Tracking
Timer													
059	TIMER2	R	-	-----	TIMER(23:16)								1MHz Timer
05A	TIMER1	R	-	-----	TIMER(15:8)								1MHz Timer
05B	TIMER0	R	-	-----	TIMER(7:0)								1MHz Timer
Wakeup Timer													
068	WAKEUPTIMER1	R	R	-----	WAKEUPTIMER(15:8)								Wakeup Timer
069	WAKEUPTIMER0	R	R	-----	WAKEUPTIMER(7:0)								Wakeup Timer
06A	WAKEUP1	RW	R	00000000	WAKEUP(15:8)								Wakeup Time
06B	WAKEUP0	RW	R	00000000	WAKEUP(7:0)								Wakeup Time
06C	WAKEUPFREQ1	RW	R	00000000	WAKEUPFREQ(15:8)								Wakeup Frequency
06D	WAKEUPFREQ0	RW	R	00000000	WAKEUPFREQ(7:0)								Wakeup Frequency
06E	WAKEUPXOEARLY	RW	R	00000000	WAKEUPXOEARLY								Wakeup Crystal Oscillator Early
Physical Layer Parameters													
Receiver Parameters													
100	IFFREQ1	RW	R	00010001	IFFREQ(15:8)								2nd LO / IF Frequency
101	IFFREQ0	RW	R	00100111	IFFREQ(7:0)								2nd LO / IF Frequency
102	DECIMATION	RW	R	-0001101	-	DECIMATION(6:0)						Decimation Factor	
103	RXDATARATE2	RW	R	00000000	RXDATARATE(23:16)								Receiver Datarate
104	RXDATARATE1	RW	R	00111101	RXDATARATE(15:8)								Receiver Datarate
105	RXDATARATE0	RW	R	10001010	RXDATARATE(7:0)								Receiver Datarate
106	MAXDROFFSET2	RW	R	00000000	MAXDROFFSET(23:16)								Maximum Receiver Datarate Offset
107	MAXDROFFSET1	RW	R	00000000	MAXDROFFSET(15:8)								Maximum Receiver Datarate Offset
108	MAXDROFFSET0	RW	R	10011110	MAXDROFFSET(7:0)								Maximum Receiver Datarate Offset
109	MAXRFOFFSET2	RW	R	0---0000	FREQ OFFS CORR	-	-	-	MAXRFOFFSET(19:16)				Maximum Receiver RF Offset

Table 28. CONTROL REGISTER MAP

Add	Name	Dir	Ret	Reset	Bit								Description
					7	6	5	4	3	2	1	0	
10A	MAXRFOFFSET1	RW	R	00010110	MAXRFOFFSET(15:8)								Maximum Receiver RF Offset
10B	MAXRFOFFSET0	RW	R	10000111	MAXRFOFFSET(7:0)								Maximum Receiver RF Offset
10C	FSKDMAX1	RW	R	00000000	FSKDEVMAX(15:8)								Four FSK Rx Deviation
10D	FSKDMAX0	RW	R	10000000	FSKDEVMAX(7:0)								Four FSK Rx Deviation
10E	FSKDMIN1	RW	R	11111111	FSKDEVMIN(15:8)								Four FSK Rx Deviation
10F	FSKDMIN0	RW	R	10000000	FSKDEVMIN(7:0)								Four FSK Rx Deviation
110	AFSKSPACE1	RW	R	—0000	—	—	—	—	AFSKSPACE(11:8)			AFSK Space (0) Frequency	
111	AFSKSPACE0	RW	R	01000000	AFSKSPACE(7:0)								AFSK Space (0) Frequency
112	AFSKMARK1	RW	R	—0000	—	—	—	—	AFSKMARK(11:8)			AFSK Mark (1) Frequency	
113	AFSKMARK0	RW	R	01110101	AFSKMARK(7:0)								AFSK Mark (1) Frequency
114	AFSKCTRL	RW	R	—00100	—	—	—	AFSKSHIFT0(4:0)			AFSK Control		
115	AMPLFILTER	RW	R	—0000	—	—	—	AMPLFILTER(3:0)			Amplitude Filter		
116	FREQUENCYLEAKAK	RW	R	—0000	—	—	—	FREQUENCYLEAK[3:0]			Baseband Frequency Recovery Loop Leakiness		
117	RXPARAMSETS	RW	R	00000000	RXPS3(1:0)		RXPS2(1:0)		RXPS1(1:0)		RXPS0(1:0)	Receiver Parameter Set Indirection	
118	RXPARAMCURSET	R	R	—	—	—	RXS(2)	RXSN(1:0)		RXSI(1:0)	Receiver Parameter Current Set		

Receiver Parameter Set 0

120	AGCGAIN0	RW	R	10110100	AGCDECAY0(3:0)				AGCATTACK0(3:0)				AGC Speed
121	AGCTARGET0	RW	R	01110110	AGCTARGET0(7:0)								AGC Target
122	AGCAHYST0	RW	R	—000	—						AGCAHYST0(2:0)		AGC Digital Threshold Range
123	AGCMINMAX0	RW	R	—000—000	—	AGCMAXDA0(2:0)			—	AGCMINDA0(2:0)			AGC Digital Min/Max Set Points
124	TIMEGAIN0	RW	R	11111000	TIMEGAIN0M				TIMEGAIN0E				Timing Gain
125	DRGAIN0	RW	R	11110010	DRGAIN0M				DRGAIN0E				Data Rate Gain
126	PHASEGAIN0	RW	R	11—0011	FILTERIDX0(1:0)		—	—	PHASEGAIN0(3:0)				Filter Index, Phase Gain
127	FREQGAINA0	RW	R	00001111	FREQ LIM0	FREQ MODULE0	FREQ HALFMOD0	FREQ AMPL GATE0	FREQGAINA0(3:0)				Frequency Gain A
128	FREQGAINB0	RW	R	00—1111	FREQ FREEZE0	FREQ AVG0	—	FREQGAINB0(4:0)				Frequency Gain B	
129	FREQGAINC0	RW	R	—01010	—	—	—	FREQGAINC0(4:0)				Frequency Gain C	
12A	FREQGAIND0	RW	R	0—01010	RFFREQ FREEZE0	—	—	FREQGAIND0(4:0)				Frequency Gain D	
12B	AMPLGAIN0	RW	R	01—0110	AMPL AVG	AMPL AGC	—	—	AMPLGAIN0(3:0)			Amplitude Gain	
12C	FREQDEV10	RW	R	—0000	—	—	—	FREQDEV0(11:8)				Receiver Frequency Deviation	
12D	FREQDEV00	RW	R	00100000	FREQDEV0(7:0)								Receiver Frequency Deviation
12E	FOURFSK0	RW	R	—10110	—	—	—	DEV UPDATE0	DEVDECAY0(3:0)			Four FSK Control	
12F	BBOFFSRES0	RW	R	10001000	RESINTB0(3:0)				RESINTA0(3:0)				Baseband Offset Compensation Resistors

Receiver Parameter Set 1

130	AGCGAIN1	RW	R	10110100	AGCDECAY1(3:0)				AGCATTACK1(3:0)				AGC Speed
131	AGCTARGET1	RW	R	01110110	AGCTARGET1(7:0)								AGC Target
132	AGCAHYST1	RW	R	—000	—						AGCAHYST1(2:0)		AGC Digital Threshold Range
133	AGCMINMAX1	RW	R	—000—000	—	AGCMAXDA1(2:0)			—	AGCMINDA1(2:0)			AGC Digital Min/Max Set Points
134	TIMEGAIN1	RW	R	11110110	TIMEGAIN1M				TIMEGAIN1E				Timing Gain
135	DRGAIN1	RW	R	11110001	DRGAIN1M				DRGAIN1E				Data Rate Gain
136	PHASEGAIN1	RW	R	11—0011	FILTERIDX1(1:0)		—	—	PHASEGAIN1(3:0)				Filter Index, Phase Gain

Table 28. CONTROL REGISTER MAP

Add	Name	Dir	Ret	Reset	Bit								Description
					7	6	5	4	3	2	1	0	
137	FREQGAINA1	RW	R	00001111	FREQ LIM1	FREQ MODULO1	FREQ HALFMOD1	FREQ AMPL GATE1	FREQGAINA1(3:0)			Frequency Gain A	
138	FREQGAINB1	RW	R	00—1111	FREQ FREEZE1	FREQ AVG1	—	FREQGAINB1(4:0)			Frequency Gain B		
139	FREQGAINC1	RW	R	—0101	—	—	—	FREQGAINC1(4:0)			Frequency Gain C		
13A	FREQGAIND1	RW	R	0—0101	RFFREQ FREEZE1	—	—	FREQGAIND1(4:0)			Frequency Gain D		
13B	AMPLGAIN1	RW	R	01—0110	AMPL AVG1	AMPL1 AGC1	—	—	AMPLGAIN1(3:0)		Amplitude Gain		
13C	FREQDEV11	RW	R	—0000	—	—	—	FREQDEV1(11:8)			Receiver Frequency Deviation		
13D	FREQDEV01	RW	R	00100000	FREQDEV1(7:0)						Receiver Frequency Deviation		
13E	FOURFSK1	RW	R	—11000	—	—	—	DEV UPDATE1	DEVDECAY1(3:0)		Four FSK Control		
13F	BBOFFSRES1	RW	R	10001000	RESINTB1(3:0)				RESINTA1(3:0)			Baseband Offset Compensation Resistors	

Receiver Parameter Set 2

140	AGCGAIN2	RW	R	11111111	AGCDECAY2(3:0)				AGCATTACK2(3:0)			AGC Speed
141	AGCTARGET2	RW	R	01110110	AGCTARGET2(7:0)						AGC Target	
142	AGCAHYST2	RW	R	—000	—					AGCAHYST2(2:0)		AGC Digital Threshold Range
143	AGCMINMAX2	RW	R	—000—000	—	AGCMAXDA2(2:0)			—	AGCMINDA2(2:0)		AGC Digital Min/Max Set Points
144	TIMEGAIN2	RW	R	11110101	TIMEGAIN2M				TIMEGAIN2E			Timing Gain
145	DRGAIN2	RW	R	11110000	DRGAIN2M				DRGAIN2E			Data Rate Gain
146	PHASEGAIN2	RW	R	11—0011	FILTERIDX2(1:0)		—	—	PHASEGAIN2(3:0)			Filter Index, Phase Gain
147	FREQGAINA2	RW	R	00001111	FREQ LIM2	FREQ MODULO2	FREQ HALFMOD2	FREQ AMPL GATE2	FREQGAINA2(3:0)			Frequency Gain A
148	FREQGAINB2	RW	R	00—1111	FREQ FREEZE2	FREQ AVG2	—	FREQGAINB2(4:0)			Frequency Gain B	
149	FREQGAINC2	RW	R	—0110	—	—	—	FREQGAINC2(4:0)			Frequency Gain C	
14A	FREQGAIND2	RW	R	0—0110	RFFREQ FREEZE2	—	—	FREQGAIND2(4:0)			Frequency Gain D	
14B	AMPLGAIN2	RW	R	01—0110	AMPL AVG2	AMPL AGC2	—	—	AMPLGAIN2(3:0)		Amplitude Gain	
14C	FREQDEV12	RW	R	—0000	—	—	—	FREQDEV2(11:8)			Receiver Frequency Deviation	
14D	FREQDEV02	RW	R	00100000	FREQDEV2(7:0)						Receiver Frequency Deviation	
14E	FOURFSK2	RW	R	—11010	—	—	—	DEV UPDATE2	DEVDECAY2(3:0)		Four FSK Control	
14F	BBOFFSRES2	RW	R	10001000	RESINTB2(3:0)				RESINTA2(3:0)			Baseband Offset Compensation Resistors

Receiver Parameter Set 3

150	AGCGAIN3	RW	R	11111111	AGCDECAY3(3:0)				AGCATTACK3(3:0)			AGC Speed
151	AGCTARGET3	RW	R	01110110	AGCTARGET3(7:0)						AGC Target	
152	AGCAHYST3	RW	R	—000	—					AGCAHYST3(2:0)		AGC Digital Threshold Range
153	AGCMINMAX3	RW	R	—000—000	—	AGCMAXDA3(2:0)			—	AGCMINDA3(2:0)		AGC Digital Min/Max Set Points
154	TIMEGAIN3	RW	R	11110101	TIMEGAIN3M				TIMEGAIN3E			Timing Gain
155	DRGAIN3	RW	R	11110000	DRGAIN3M				DRGAIN3E			Data Rate Gain
156	PHASEGAIN3	RW	R	11—0011	FILTERIDX3(1:0)		—	—	PHASEGAIN3(3:0)			Filter Index, Phase Gain
157	FREQGAINA3	RW	R	00001111	FREQ LIM3	FREQ MODULO3	FREQ HALFMOD3	FREQ AMPL GATE3	FREQGAINA3(3:0)			Frequency Gain A
158	FREQGAINB3	RW	R	00—1111	FREQ FREEZE3	FREQ AVG3	—	FREQGAINB3(4:0)			Frequency Gain B	
159	FREQGAINC3	RW	R	—0110	—	—	—	FREQGAINC3(4:0)			Frequency Gain C	

Table 28. CONTROL REGISTER MAP

Add	Name	Dir	Ret	Reset	Bit								Description
					7	6	5	4	3	2	1	0	
15A	FREQGAIN3	RW	R	0—01101	RFFREQ FREEZE3	—	—	FREQGAIN3(4:0)				Frequency Gain D	
15B	AMPLGAIN3	RW	R	01—0110	AMPL AVG3	AMPL AGC3	—	—	AMPLGAIN3(3:0)			Amplitude Gain	
15C	FREQDEV13	RW	R	—0000	—	—	—	FREQDEV3(11:8)				Receiver Frequency Deviation	
15D	FREQDEV03	RW	R	00100000	FREQDEV3(7:0)						Receiver Frequency Deviation		
15E	FOURFSK3	RW	R	—11010	—	—	—	DEV UPDATE3	DEVDECAY3(3:0)			Four FSK Control	
15F	BBOFFSRES3	RW	R	10001000	RESINTB3(3:0)				RESINTA3(3:0)				Baseband Offset Compensation Resistors

Transmitter Parameters

160	MODCFGF	RW	R	—00	—	—	—	—	—	—	FREQ SHAPE	Modulator Configuration F	
161	FSKDEV2	RW	R	00000000	FSKDEV(23:16)							FSK Frequency Deviation	
162	FSKDEV1	RW	R	00001010	FSKDEV(15:8)							FSK Frequency Deviation	
163	FSKDEV0	RW	R	00111101	FSKDEV(7:0)							FSK Frequency Deviation	
164	MODCFG A	RW	R	0000—101	BROWN GATE	PTTLCK GATE	SLOW RAMP		—	AMPL SHAPE	TX SE	TX DIFF	Modulator Configuration A
165	TXRATE2	RW	R	00000000	TXRATE(23:16)							Transmitter Bitrate	
166	TXRATE1	RW	R	00101000	TXRATE(15:8)							Transmitter Bitrate	
167	TXRATE0	RW	R	11110110	TXRATE(7:0)							Transmitter Bitrate	
168	TXPWRCOEFF A1	RW	R	00000000	TXPWRCOEFFA(15:8)							Transmitter Predistortion Coefficient A	
169	TXPWRCOEFF A0	RW	R	00000000	TXPWRCOEFFA(7:0)							Transmitter Predistortion Coefficient A	
16A	TXPWRCOEFF B1	RW	R	00001111	TXPWRCOEFFB(15:8)							Transmitter Predistortion Coefficient B	
16B	TXPWRCOEFF B0	RW	R	11111111	TXPWRCOEFFB(7:0)							Transmitter Predistortion Coefficient B	
16C	TXPWRCOEFF C1	RW	R	00000000	TXPWRCOEFFC(15:8)							Transmitter Predistortion Coefficient C	
16D	TXPWRCOEFF C0	RW	R	00000000	TXPWRCOEFFC(7:0)							Transmitter Predistortion Coefficient C	
16E	TXPWRCOEFF D1	RW	R	00000000	TXPWRCOEFFD(15:8)							Transmitter Predistortion Coefficient D	
16F	TXPWRCOEFF D0	RW	R	00000000	TXPWRCOEFFD(7:0)							Transmitter Predistortion Coefficient D	
170	TXPWRCOEFF E1	RW	R	00000000	TXPWRCOEFFE(15:8)							Transmitter Predistortion Coefficient E	
171	TXPWRCOEFF E0	RW	R	00000000	TXPWRCOEFFE(7:0)							Transmitter Predistortion Coefficient E	

PLL Parameters

180	PLLVC0I	RW	R	0—010010	VCOIE	—	VCOI(5:0)					VCO Current
181	PLLVC0IR	RW	R	—	—	—	VCOIR(5:0)					VCO Current Readback
182	PLLLOCKDET	RW	R	—011	LOCKDETLYR		—	—	—	LOCK DET DLYM	LOCKDETDLY	PLL Lock Detect Delay
183	PLLRNGCLK	RW	R	—011	—	—	—	—	—	PLLRNGCLK(2:0)		PLL Ranging Clock

Crystal Oscillator

184	XTALCAP	RW	R	00000000	XTALCAP(7:0)							Crystal Oscillator Load Capacitance
-----	---------	----	---	----------	--------------	--	--	--	--	--	--	-------------------------------------

Table 28. CONTROL REGISTER MAP

Add	Name	Dir	Ret	Reset	Bit								Description
					7	6	5	4	3	2	1	0	
Baseband													
188	BBTUNE	RW	R	—01001	—	—	—	BB TUNE RUN	BBTUNE(3:0)			Baseband Tuning	
189	BBOFFSCAP	RW	R	—111—111	—	CAP INT B(2:0)			—	CAP INT A(2:0)		Baseband Offset Compensation Capacitors	
MAC Layer Parameters													
Packet Format													
200	PKTADDRCFG	RW	R	001—0000	MSB FIRST	CRC SKIP FIRST	FEC SYNC DIS	—	ADDR POS(3:0)			Packet Address Config	
201	PKTLENCFG	RW	R	00000000	LEN BITS(3:0)				LEN POS(3:0)			Packet Length Config	
202	PKTLENOFFSET	RW	R	00000000	LEN OFFSET(7:0)							Packet Length Offset	
203	PKTMAXLEN	RW	R	00000000	MAX LEN(7:0)							Packet Maximum Length	
204	PKTADDR3	RW	R	00000000	ADDR(31:24)							Packet Address 3	
205	PKTADDR2	RW	R	00000000	ADDR(23:16)							Packet Address 2	
206	PKTADDR1	RW	R	00000000	ADDR(15:8)							Packet Address 1	
207	PKTADDR0	RW	R	00000000	ADDR(7:0)							Packet Address 0	
208	PKTADDRMASK3	RW	R	00000000	ADDRMASK(31:24)							Packet Address Mask 1	
209	PKTADDRMASK2	RW	R	00000000	ADDRMASK(23:16)							Packet Address Mask 0	
20A	PKTADDRMASK1	RW	R	00000000	ADDRMASK(15:8)							Packet Address Mask 1	
20B	PKTADDRMASK0	RW	R	00000000	ADDRMASK(7:0)							Packet Address Mask 0	
Pattern Match													
210	MATCH0PAT3	RW	R	00000000	MATCH0PAT(31:24)							Pattern Match Unit 0, Pattern	
211	MATCH0PAT2	RW	R	00000000	MATCH0PAT(23:16)							Pattern Match Unit 0, Pattern	
212	MATCH0PAT1	RW	R	00000000	MATCH0PAT(15:8)							Pattern Match Unit 0, Pattern	
213	MATCH0PAT0	RW	R	00000000	MATCH0PAT(7:0)							Pattern Match Unit 0, Pattern	
214	MATCH0LEN	RW	R	0—00000	MATCH0 RAW	—	—	MATCH0LEN				Pattern Match Unit 0, Pattern Length	
215	MATCH0MIN	RW	R	—00000	—	—	—	MATCH0MIN				Pattern Match Unit 0, Minimum Match	
216	MATCH0MAX	RW	R	—11111	—	—	—	MATCH0MAX				Pattern Match Unit 0, Maximum Match	
218	MATCH1PAT1	RW	R	00000000	MATCH1PAT(15:8)							Pattern Match Unit 1, Pattern	
219	MATCH1PAT0	RW	R	00000000	MATCH1PAT(7:0)							Pattern Match Unit 1, Pattern	
21C	MATCH1LEN	RW	R	0—0000	MATCH1 RAW	—	—	—	MATCH1LEN			Pattern Match Unit 1, Pattern Length	
21D	MATCH1MIN	RW	R	—0000	—	—	—	—	MATCH1MIN			Pattern Match Unit 1, Minimum Match	
21E	MATCH1MAX	RW	R	—1111	—	—	—	—	MATCH1MAX			Pattern Match Unit 1, Maximum Match	
Packet Controller													
220	TMGTXBBOOST	RW	R	00110010	TMGTXBBOOSTE				TMGTXBBOOSTM				Transmit PLL Boost Time
221	TMGTXSETTLE	RW	R	00001010	TMGTXSETTLEE				TMGTXSETTLEM				Transmit PLL (post Boost) Settling Time
223	TMGRXBBOOST	RW	R	00110010	TMGRXBBOOSTE				TMGRXBBOOSTM				Receive PLL Boost Time
224	TMGRXSETTLE	RW	R	00010100	TMGRXSETTLEE				TMGRXSETTLEM				Receive PLL (post Boost) Settling Time
225	TMGRXOFFSACQ	RW	R	01110011	TMGRXOFFSACQE				TMGRXOFFSACQM				Receive Baseband DC Offset Acquisition Time
226	TMGRXCOARSEAGC	RW	R	00111001	TMGRXCOARSEAGCE				TMGRXCOARSEAGCM				Receive Coarse AGC Time

Table 28. CONTROL REGISTER MAP

Add	Name	Dir	Ret	Reset	Bit								Description
					7	6	5	4	3	2	1	0	
227	TMGRXAGC	RW	R	00000000	TMGRXAGCE				TMGRXAGCM				Receiver AGC Settling Time
228	TMGRXRSSI	RW	R	00000000	TMGRXRSSIE				TMGRXRSSIM				Receiver RSSI Settling Time
229	TMGRXPREAMBLE1	RW	R	00000000	TMGRXPREAMBLE1E				TMGRXPREAMBLE1M				Receiver Preamble 1 Timeout
22A	TMGRXPREAMBLE2	RW	R	00000000	TMGRXPREAMBLE2E				TMGRXPREAMBLE2M				Receiver Preamble 2 Timeout
22B	TMGRXPREAMBLE3	RW	R	00000000	TMGRXPREAMBLE3E				TMGRXPREAMBLE3M				Receiver Preamble 3 Timeout
22C	RSSIREFERENCE	RW	R	00000000	RSSIREFERENCE								RSSI Offset
22D	RSSIABSTHR	RW	R	00000000	RSSIABSTHR								RSSI Absolute Threshold
22E	BGNDRSSIGAIN	RW	R	—0000	—	—	—	—	BGNDRSSIGAIN				Background RSSI Averaging Time Constant
22F	BGNDRSSITHR	RW	R	—000000	—	—	BGNDRSSITHR					Background RSSI Relative Threshold	
230	PKTCHUNKSIZE	RW	R	—0000	—	—	—	PKTCHUNKSIZE(3:0)				Packet Chunk Size	
231	PKTMISCFLAGS	RW	R	—00000	—	—	—	WOR MULTI PKT	AGC SETTL DET	BGND RSSI	RXAGC CLK	RXRSSI CLK	Packet Controller Miscellaneous Flags
232	PKTSTOREFLAGS	RW	R	—0000000	—	ST ANT RSSI	ST CRCB	ST RSSI	ST DR	ST RFOFFS	ST FOFFS	ST TIMER	Packet Controller Store Flags
233	PKTACCEPTFLAGS	RW	R	—000000	—	—	ACCPT LRGP	ACCPT SZF	ACCPT ADDR	ACCPT CRCF	ACCPT ABRT	ACCPT RESIDUE	Packet Controller Accept Flags

Special Functions

General Purpose ADC

300	GPADCCTRL	RW	R	—000000	BUSY	—	0	0	0	GPADC13	CONT	CH ISOL	General Purpose ADC Control
301	GPADCPERIOD	RW	R	00111111	GPADCPERIOD(7:0)								GPADC Sampling Period
308	GPADC13VALUE1	R		—	—	—	—	—	—	GPADC13VALUE(9:8)		GPADC13 Value	
309	GPADC13VALUE0	R		—	GPADC13VALUE(7:0)								GPADC13 Value

Low Power Oscillator Calibration

310	LPOSCCONFIG	RW		00000000	LPOSC OSC INVERT	LPOSC OSC DOUBLE	LPOSC CALIBR	LPOSC CALIBF	LPOSC IRQR	LPOSC IRQF	LPOSC FAST	LPOSC ENA	Low Power Oscillator Configuration
311	LPOSCSTATUS	R		—	—	—	—	—	—	—	LPOSC IRQ	LPOSC EDGE	Low Power Oscillator Status
312	LPOSCFILT1	RW		00100000	LPOSCFILT(15:8)								Low Power Oscillator Calibration Filter Constant
313	LPOSCFILT0	RW		11000100	LPOSCFILT(7:0)								Low Power Oscillator Calibration Filter Constant
314	LPOSCREF1	RW		01100001	LPOSCREF(15:8)								Low Power Oscillator Calibration Reference
315	LPOSCREF0	RW		10101000	LPOSCREF(7:0)								Low Power Oscillator Calibration Reference
316	LPOSCFREQ1	RW		00000000	LPOSCFREQ(9:2)								Low Power Oscillator Calibration Frequency
317	LPOSCFREQ0	RW		0000—	LPOSCFREQ(1:-2)				—	—	—	—	Low Power Oscillator Calibration Frequency
318	LPOSCPER1	RW		—	LPOSCPER(15:8)								Low Power Oscillator Calibration Period
319	LPOSCPER0	RW		—	LPOSCPER(7:0)								Low Power Oscillator Calibration Period

DAC

330	DACVALUE1	RW	R	—0000	—	—	—	DACVALUE(11:8)					DAC Value
331	DACVALUE2	RW	R	00000000	DACVALUE(7:0)								DAC Value
332	DACCONFIG	RW	R	00—0000	DAC PWM	DAC CLK X2	—	—	DACINPUT(3:0)				DAC Configuration

APPLICATION INFORMATION

Typical Application Diagrams

Match to 50 Ω for Differential Antenna Pins
(868 / 915 / 433 / 169 MHz RX / TX Operation)

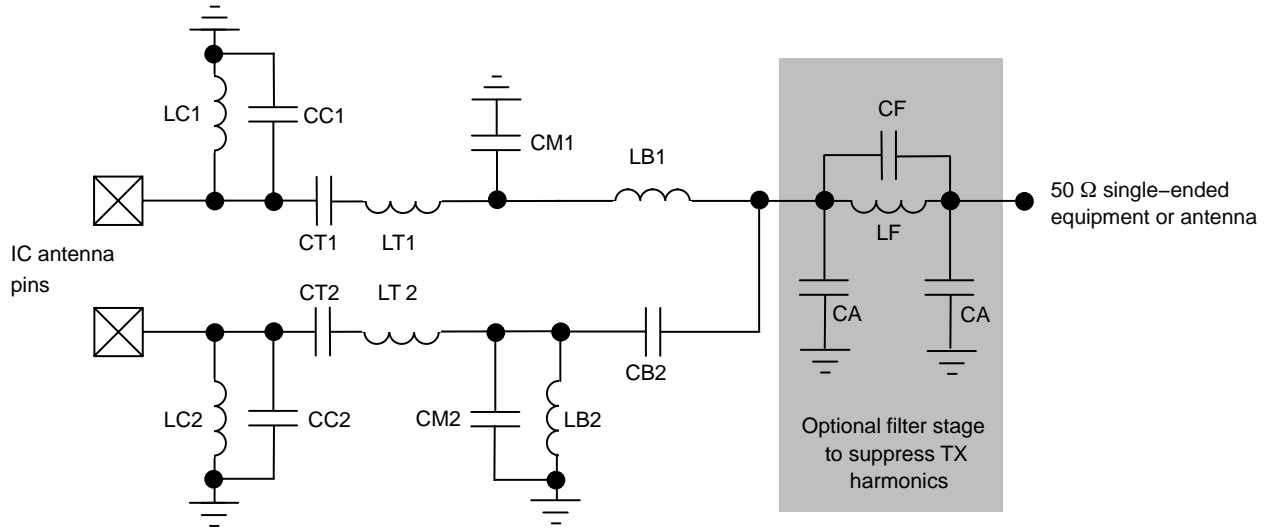

Figure 10. Structure of the Differential Antenna Interface for TX/RX Operation to 50 Ω Single-ended Equipment or Antenna

Table 29. TYPICAL COMPONENT VALUES

Frequency Band	LC1,2 [nH]	CC1,2 [pF]	CT1,2 [pF]	LT1,2 [nH]	CM1 [pF]	CM2 [pF]	LB1,2 [nH]	CB2 [pF]	CF [pF] optional	LF [nH] optional	CA [pF] optional
868 / 915 MHz	18	nc	2.7	18	6.2	3.6	12	2.7	nc	0 Ω	nc
433 MHz	100	nc	4.3	43	11	5.6	27	5.1	nc	0 Ω	nc
470 MHz	100	nc	3.9	33	4.7	nc	22	4.7	nc	0 Ω	nc
169 MHz	150	10	10	120	12	nc	68	12	6.8	30	27

Match to 50 Ω for Single-ended Antenna Pin
(868 / 915 / 433 MHz TX Operation)

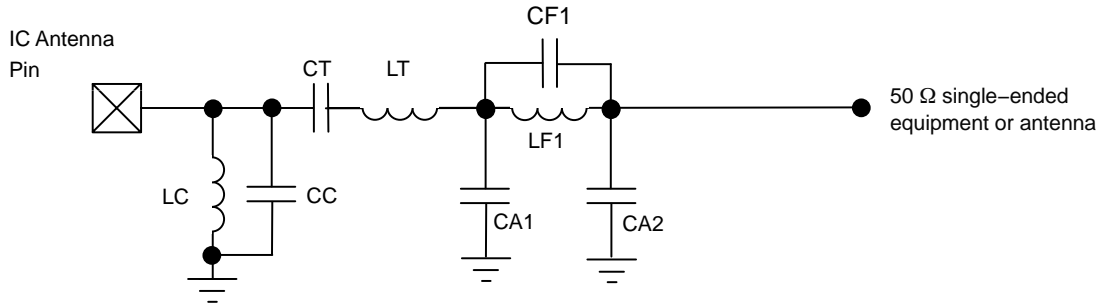

Figure 11. Structure of the Single-ended Antenna Interface for TX Operation to 50 Ω Single-ended Equipment or Antenna

Table 30. TYPICAL COMPONENT VALUES

Frequency Band	LC [nH]	CC [pF]	CT [pF]	LT [nH]	CF1 [pF]	LF1 [nH]	CA1 [pF]	CA2 [pF]
868 / 915 MHz	18	nc	2.7	18	3.6	2.2	3.6	nc
433 MHz	100	nc	4.3	43	6.8	4.7	5.6	nc

Match to 50 Ω for Single-ended Antenna Pin
(169 MHz TX Operation)

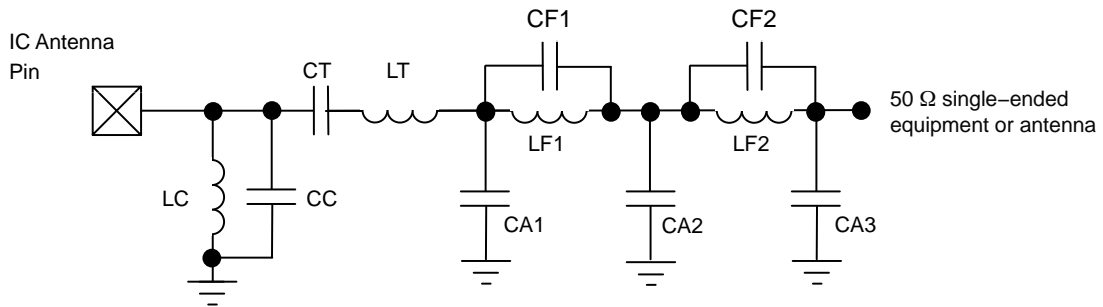

Figure 12. Structure of the Single-ended Antenna Interface for TX Operation to 50 Ω Single-ended Equipment or Antenna

Table 31. TYPICAL COMPONENT VALUES

Frequency Band	LC [nH]	CC [pF]	CT [pF]	LT [nH]	CF1 [pF]	LF1 [nH]	CF2 [pF]	LF2 [nH]	CA1 [pF]	CA2 [pF]	CA3 [pF]
169 MHz	150	2.2	22	120	4.7	39	1.8	47	33	47	15

AX5043

Using a Dipole Antenna and the Internal TX/RX Switch

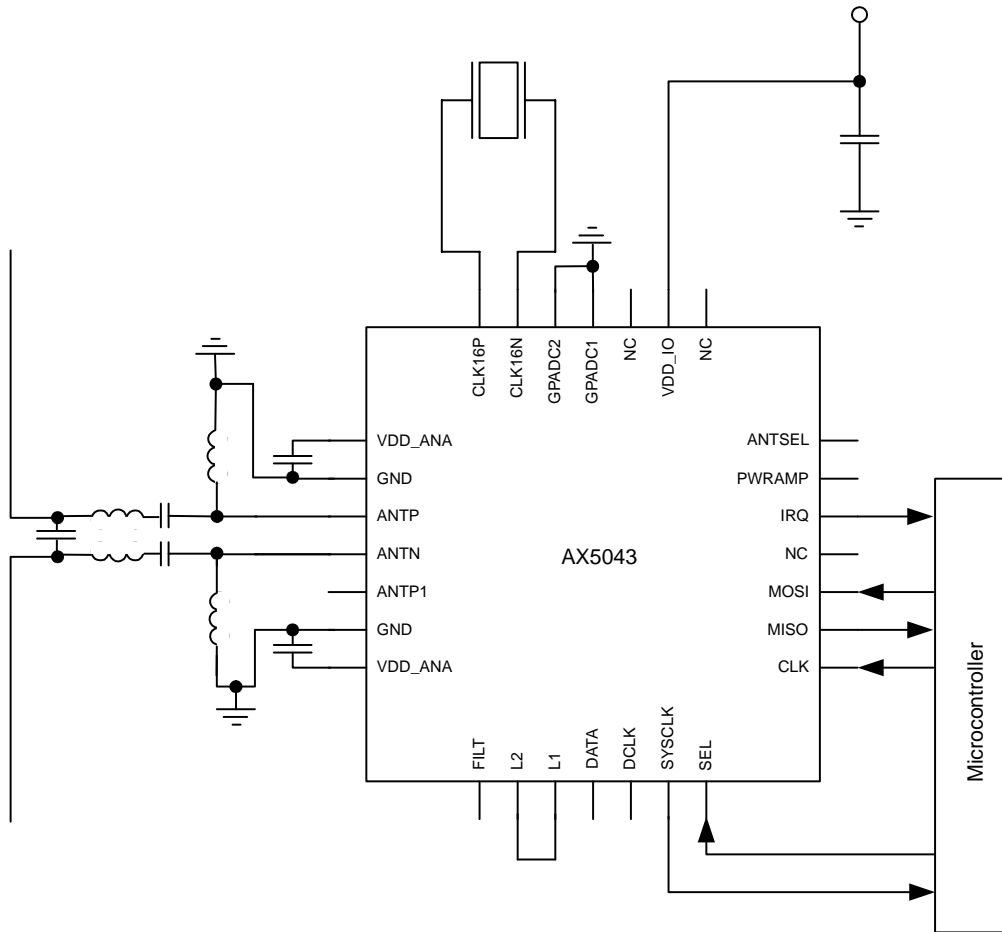

Figure 13. Typical Application Diagram with Dipole Antenna and Internal TX/RX Switch

AX5043

Using a Single-ended Antenna and the Internal TX/RX Switch

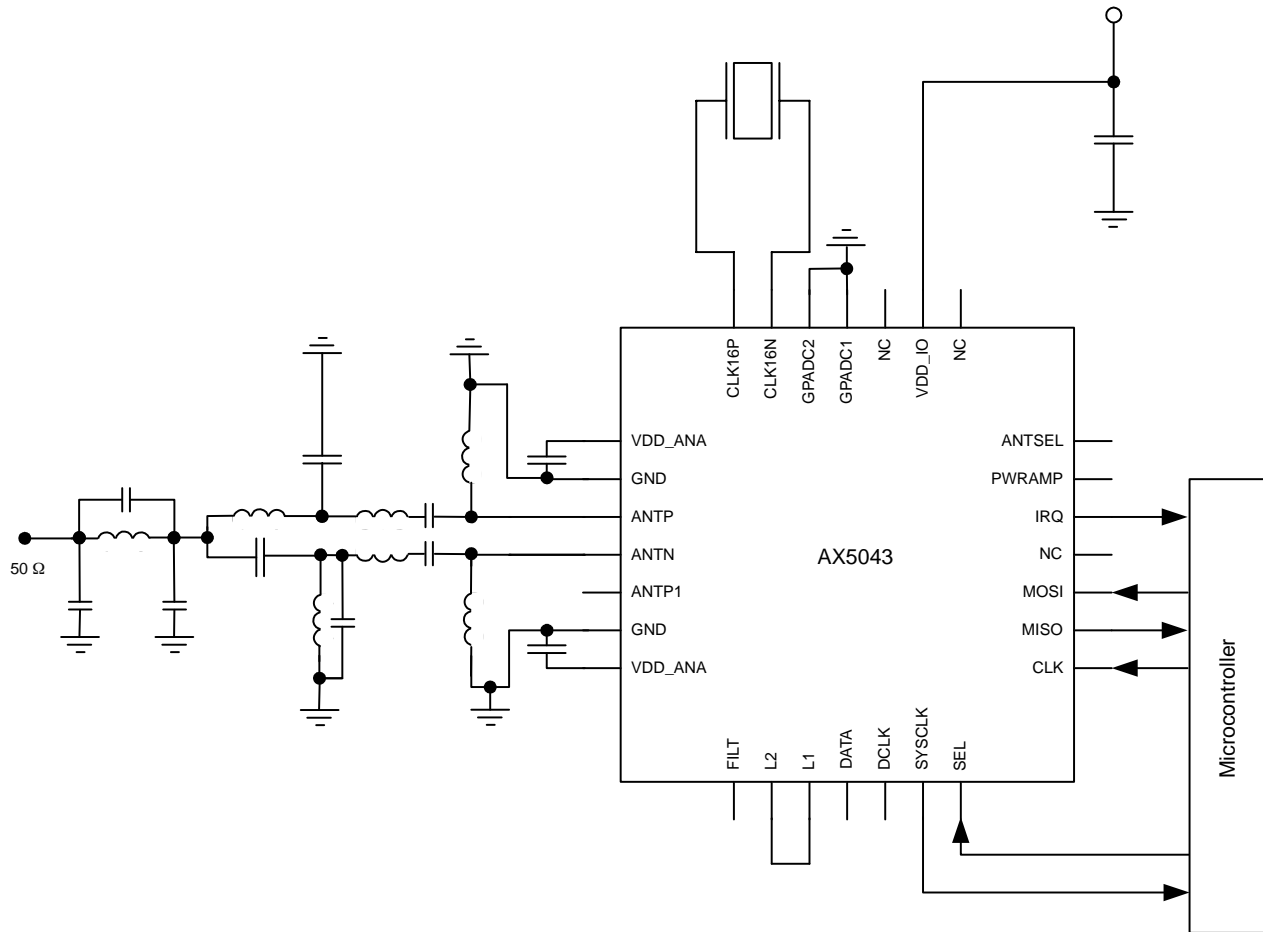

Figure 14. Typical Application Diagram with Single-ended Antenna and Internal TX/RX Switch

AX5043

Using an External High-power PA and an External TX/RX Switch

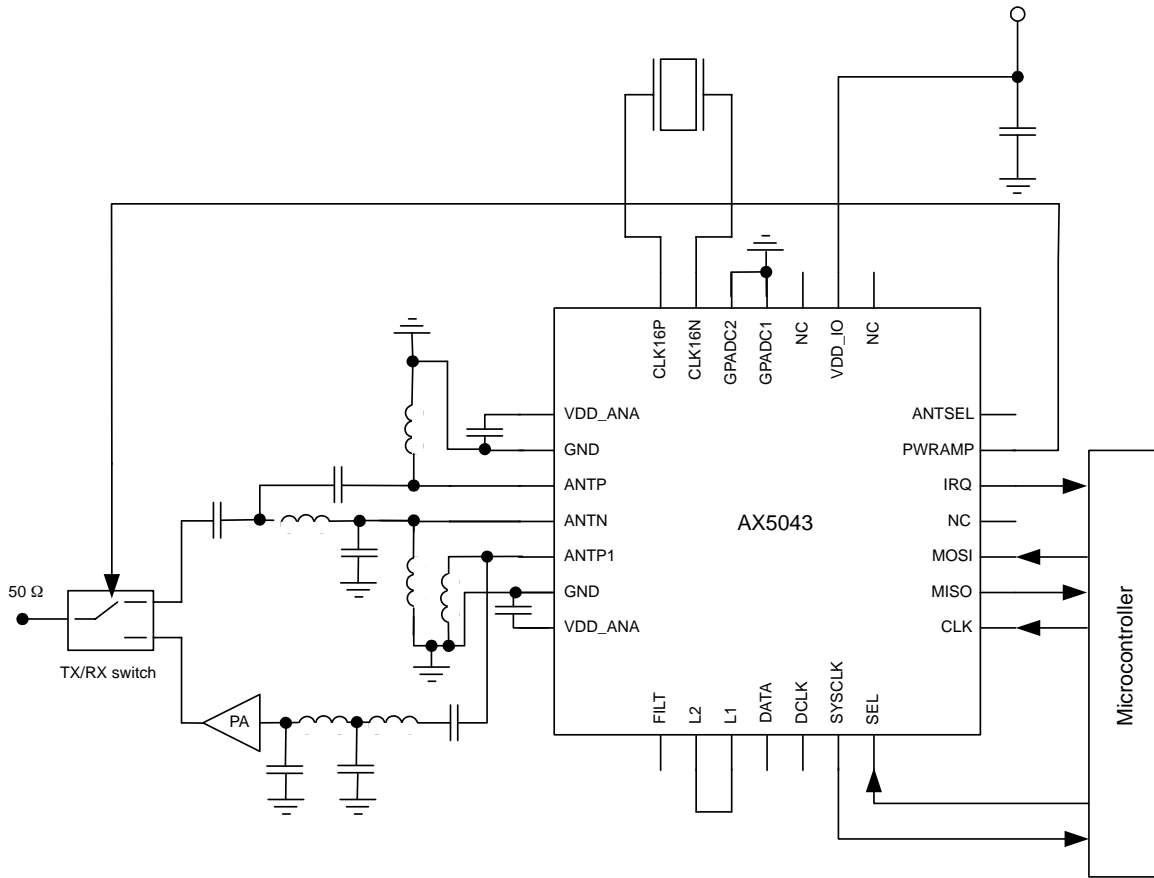

Figure 15. Typical Application Diagram with Single-ended Antenna, External PA and External Antenna Switch

AX5043

Using the Single-ended PA

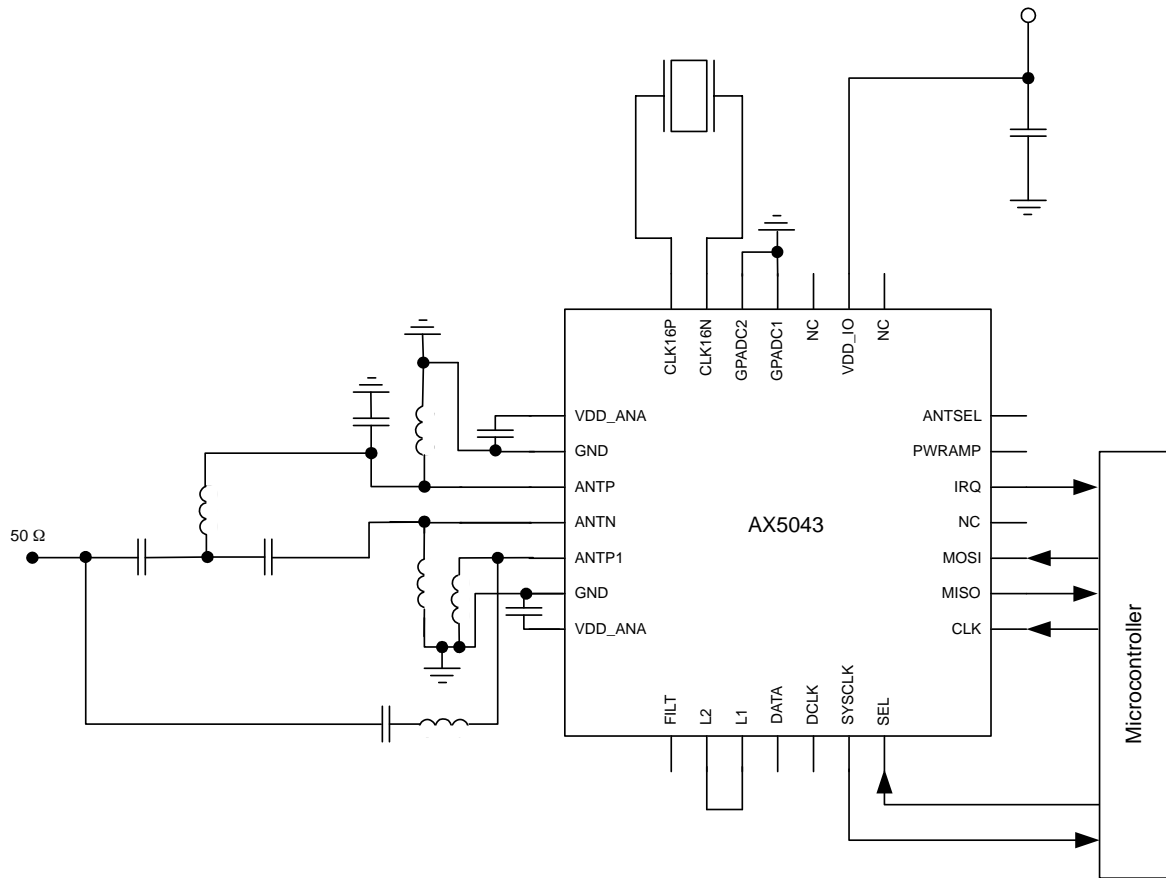

Figure 16. Typical Application Diagram with Single-ended Antenna, Single-ended Internal PA, without RX/TX Switch

NOTE: For details and recommendations on implementing this configuration refer to the AX5043 Application Note: 0 dBm / 8 mA TX and 9.5 mA RX Configuration for the 868 MHz Band.

AX5043

Using Two Antenna

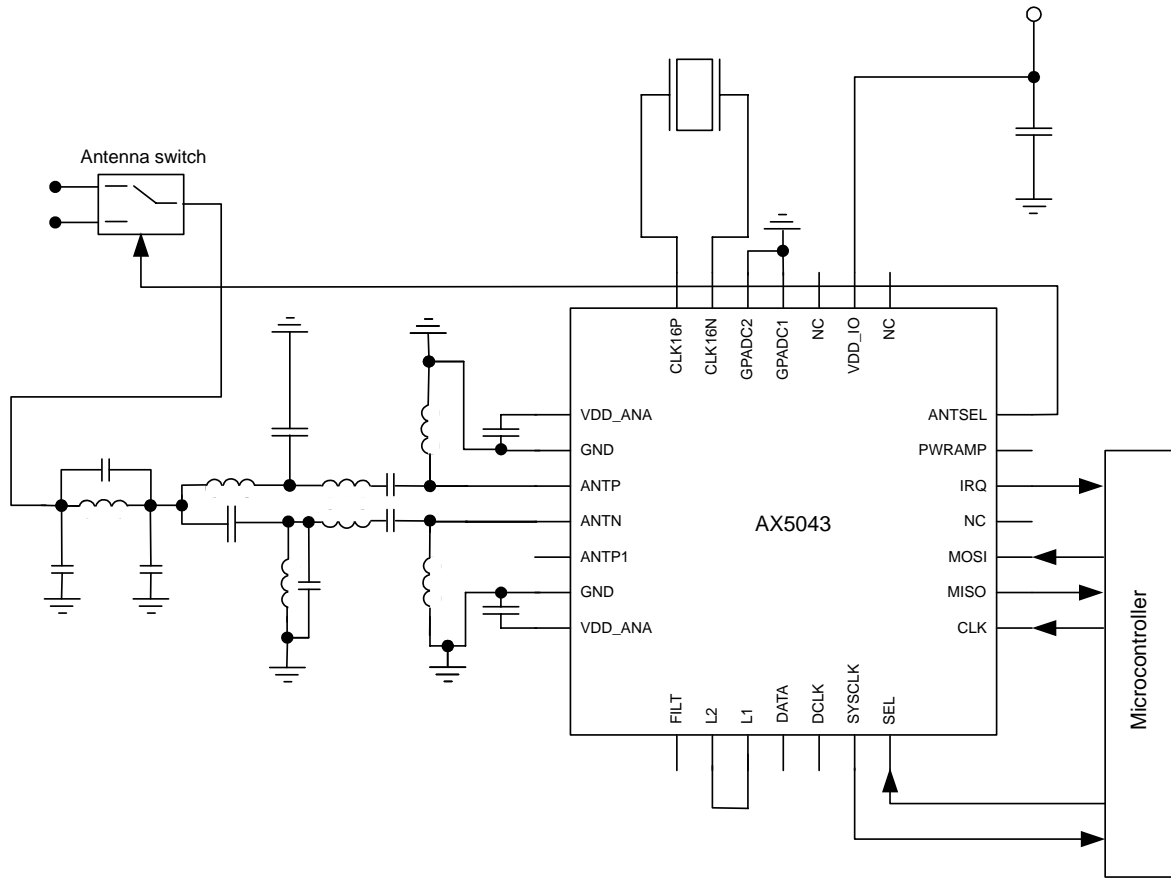

Figure 17. Typical Application Diagram with Two Single-ended Antenna and External Antenna Switch

AX5043

Using an External VCO Inductor

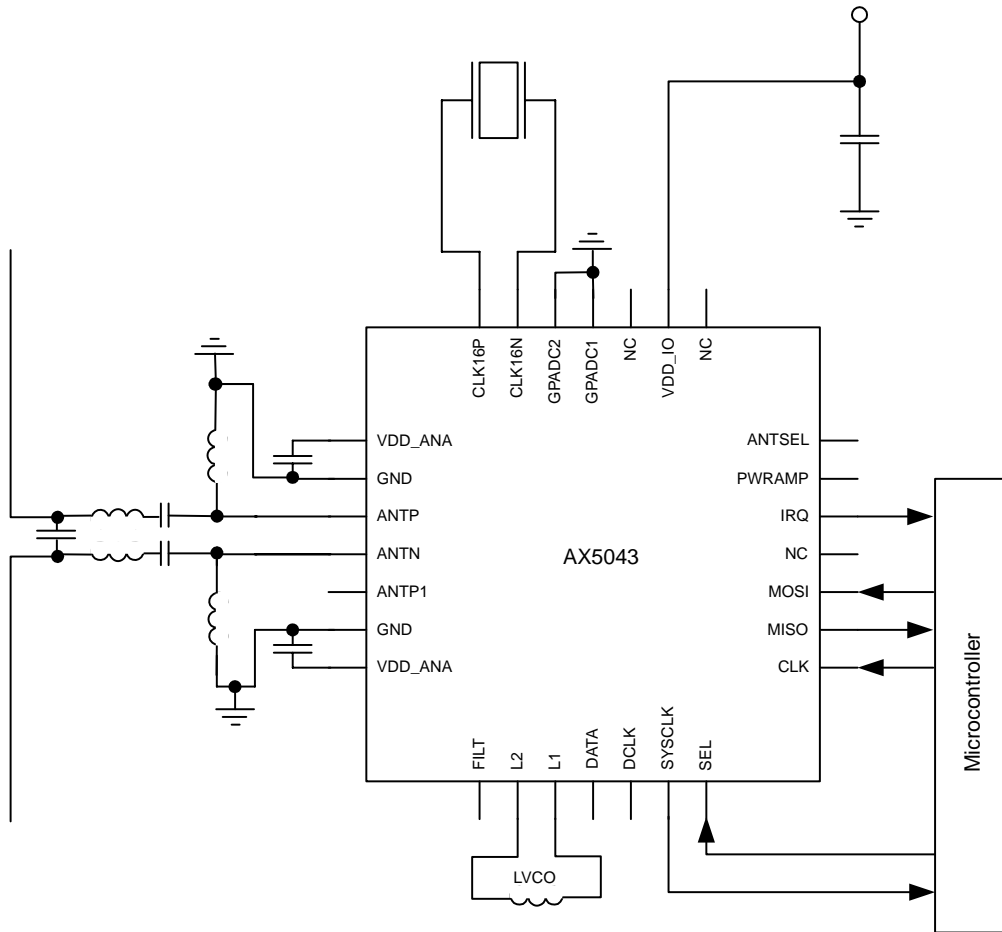

Figure 18. Typical Application Diagram with External VCO Inductor

AX5043

Using an External VCO

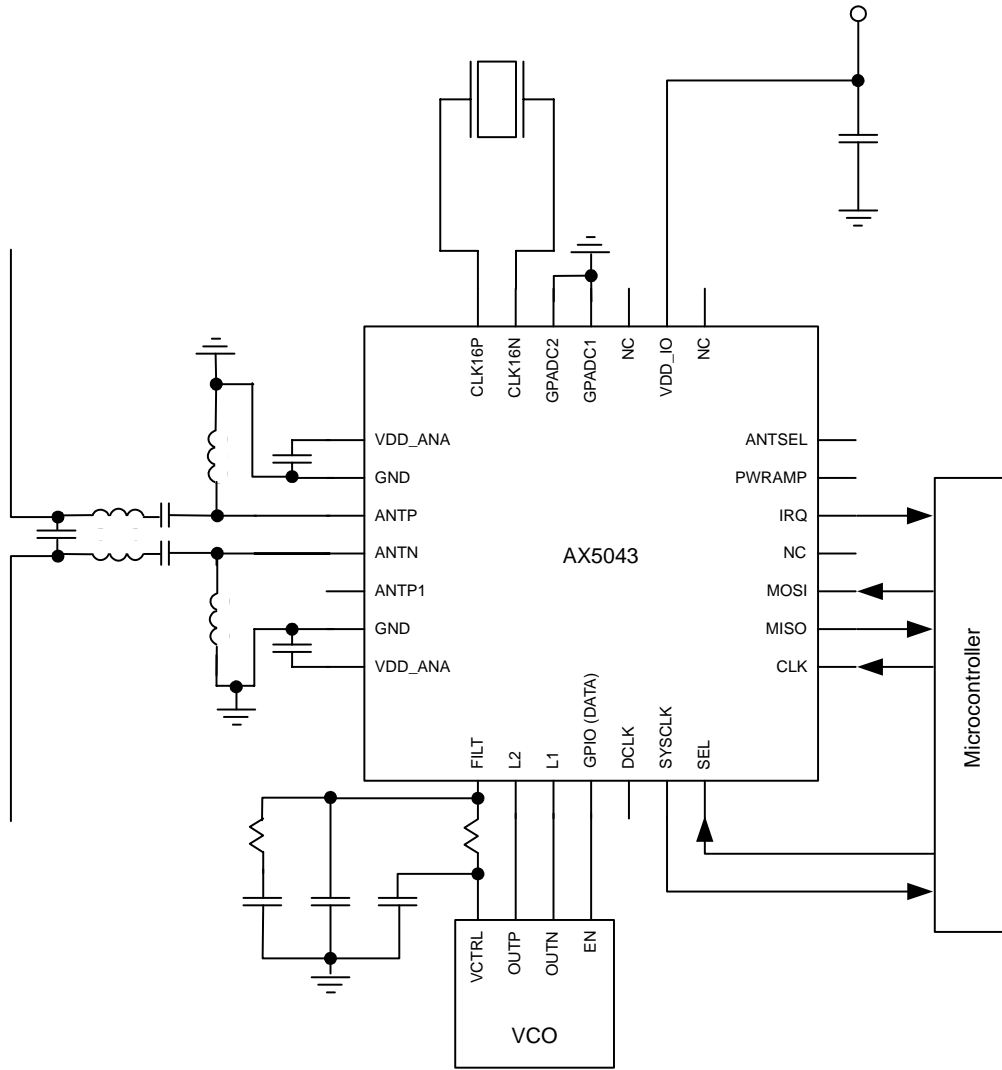
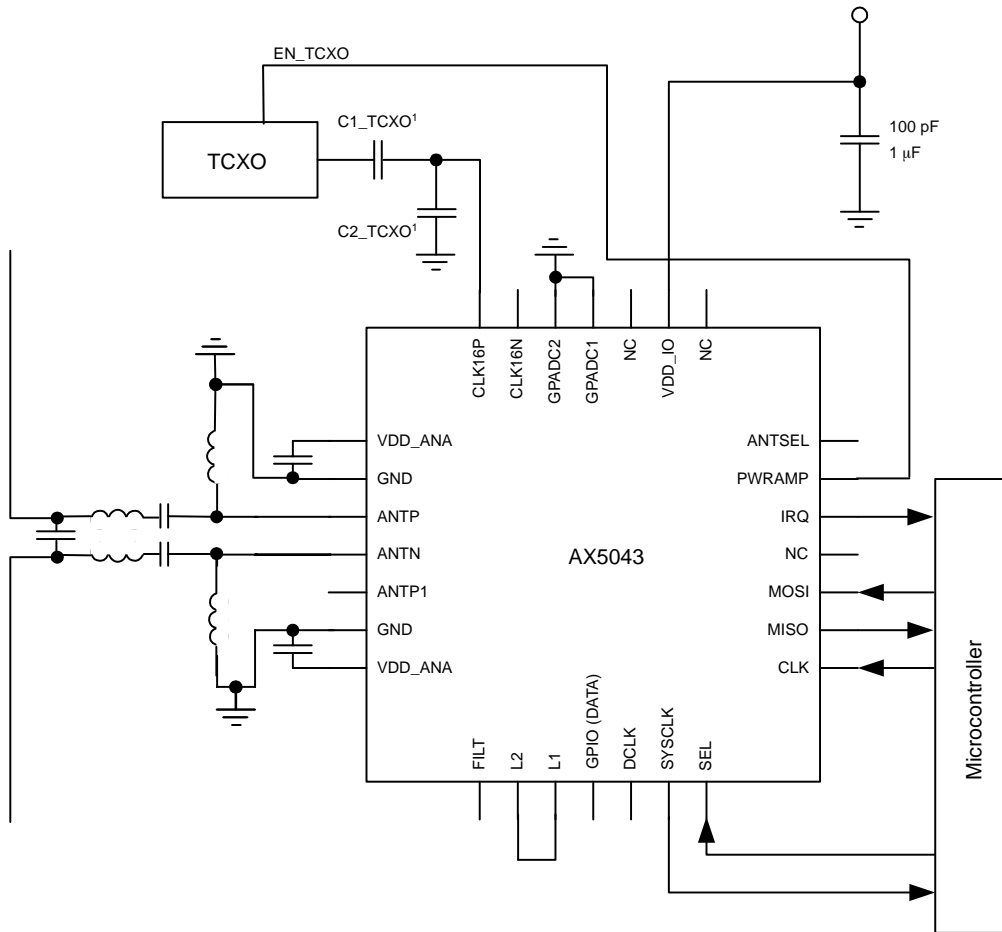

Figure 19. Typical Application Diagram with External VCO

AX5043

Using a TCXO



Note 1: For detailed TCXO network recommendations depending on TCXO output swing refer to the AX5043 Application Note: Use with a TCXO Reference Clock.

Figure 20. Typical Application Diagram with a TCXO

AX5043

QFN28 PACKAGE INFORMATION

Package Outline QFN28 5 mm x 5 mm

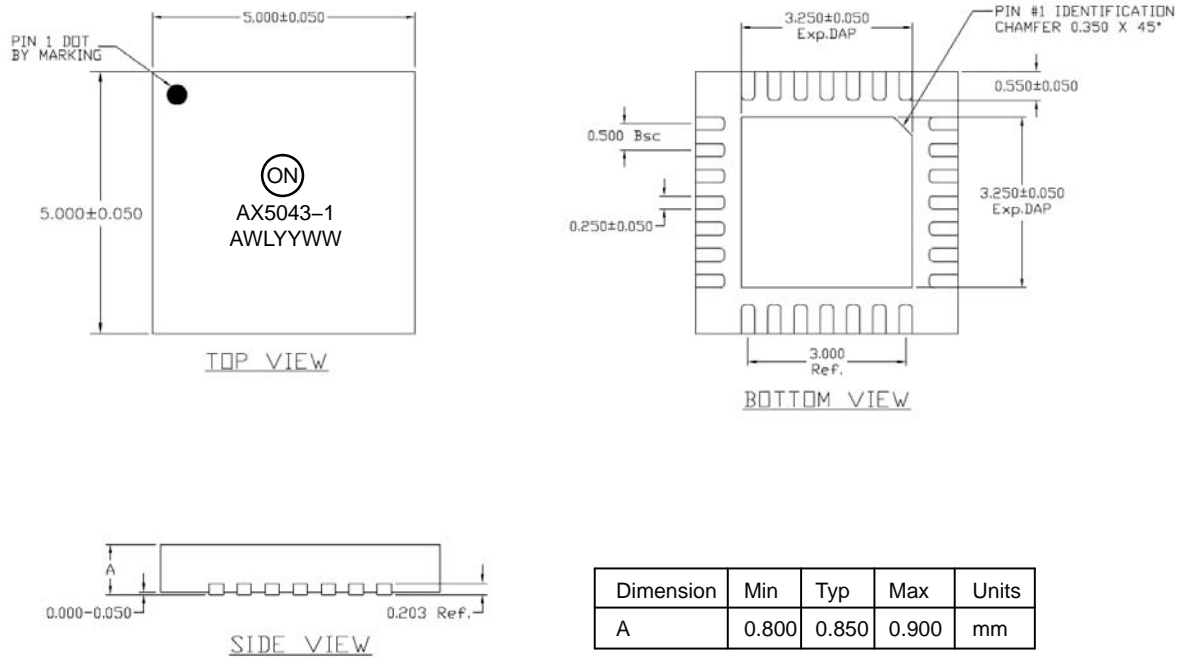

NOTES:

1. JEDEC ref MO-220
2. All dimensions are in millimeters
3. Pin 1 is identified by chamfer on corner of exposed die pad
4. Package warp is 0.050 maximum
5. Coplanarity applies to the exposed pad as well as the terminal
6. AWLYYWW is the packaging lot code
7. RoHS

Figure 21. Package Outline QFN28 5 mm x 5 mm

QFN28 Soldering Profile

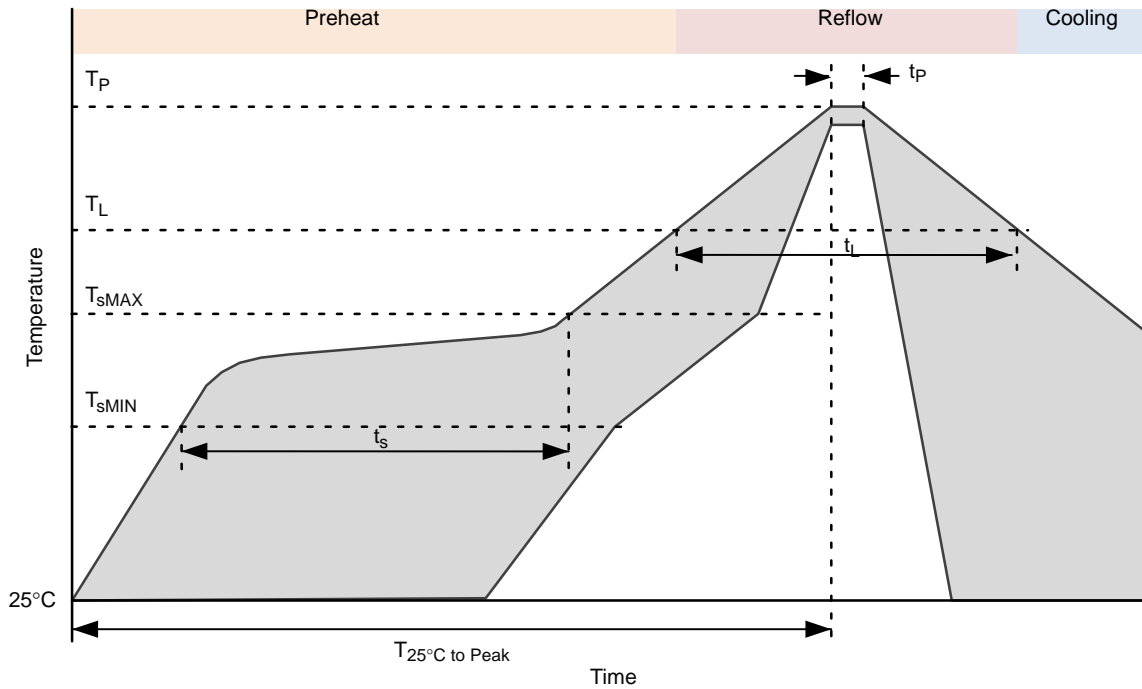

Figure 22. QFN40 Soldering Profile

Table 32.

Profile Feature	Pb-Free Process
Average Ramp-Up Rate	3°C/s max.
Preheat Preheat	
Temperature Min	T_{SMIN} 150°C
Temperature Max	T_{SMAX} 200°C
Time (T_{SMIN} to T_{SMAX})	t_s 60 – 180 sec
Time 25°C to Peak Temperature	$T_{25^\circ C \text{ to Peak}}$ 8 min max.
Reflow Phase	
Liquidus Temperature	T_L 217°C
Time over Liquidus Temperature	t_L 60 – 150 s
Peak Temperature	t_p 260°C
Time within 5°C of actual Peak Temperature	T_p 20 – 40 s
Cooling Phase	
Ramp-down rate	6°C/s max.

1. All temperatures refer to the top side of the package, measured on the the package body surface.

QFN28 Recommended Pad Layout

1. PCB land and solder masking recommendations are shown in Figure 23.

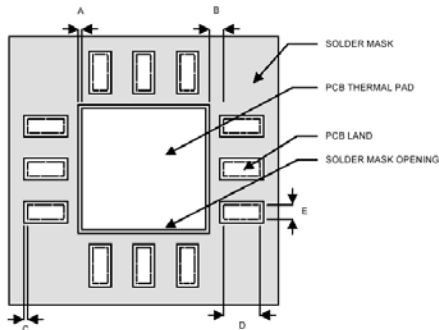

- A = Clearance from PCB thermal pad to solder mask opening, 0.0635 mm minimum
- B = Clearance from edge of PCB thermal pad to PCB land, 0.2 mm minimum
- C = Clearance from PCB land edge to solder mask opening to be as tight as possible to ensure that some solder mask remains between PCB pads.
- D = PCB land length = QFN solder pad length + 0.1 mm
- E = PCB land width = QFN solder pad width + 0.1 mm

Figure 23. PCB Land and Solder Mask Recommendations

2. Thermal vias should be used on the PCB thermal pad (middle ground pad) to improve thermal conductivity from the device to a copper ground plane area on the reverse side of the printed circuit board. The number of vias depends on the package thermal requirements, as determined by thermal simulation or actual testing.
3. Increasing the number of vias through the printed circuit board will improve the thermal conductivity to the reverse side ground plane and external heat sink. In general, adding more metal through the PCB under the IC will improve operational heat transfer, but will require careful attention to uniform heating of the board during assembly.

Assembly Process

Stencil Design & Solder Paste Application

1. Stainless steel stencils are recommended for solder paste application.
2. A stencil thickness of 0.125 – 0.150 mm (5 – 6 mils) is recommended for screening.

3. For the PCB thermal pad, solder paste should be printed on the PCB by designing a stencil with an array of smaller openings that sum to 50% of the QFN exposed pad area. Solder paste should be applied through an array of squares (or circles) as shown in Figure 24.
4. The aperture opening for the signal pads should be between 50–80% of the QFN pad area as shown in Figure 25.
5. Optionally, for better solder paste release, the aperture walls should be trapezoidal and the corners rounded.
6. The fine pitch of the IC leads requires accurate alignment of the stencil and the printed circuit board. The stencil and printed circuit assembly should be aligned to within + 1 mil prior to application of the solder paste.
7. No-clean flux is recommended since flux from underneath the thermal pad will be difficult to clean if water-soluble flux is used.

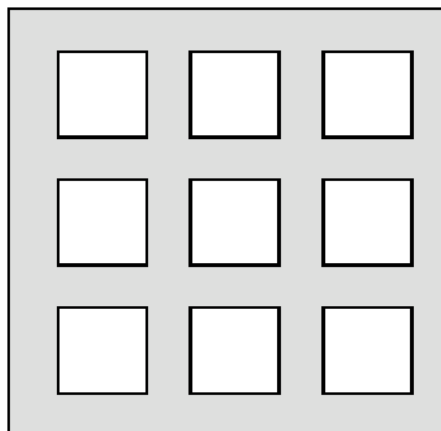

Figure 24. Solder Paste Application on Exposed Pad

AX5043

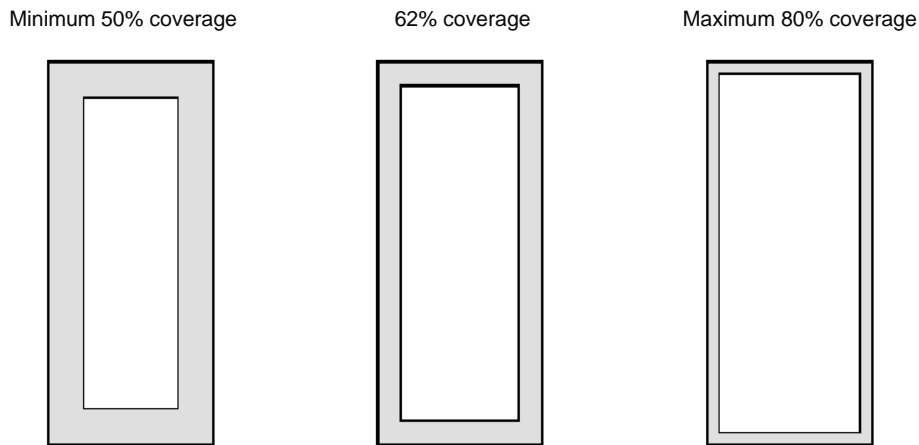



Figure 25. Solder Paste Application on Pins

Life Support Applications

This product is not designed for use in life support appliances, devices, or in systems where malfunction of this product can reasonably be expected to result in personal injury. AXSEM customers using or selling this product for

use in such applications do so at their own risk and agree to fully indemnify AXSEM for any damages resulting from such improper use or sale.

ON Semiconductor and the  are registered trademarks of Semiconductor Components Industries, LLC (SCILLC) or its subsidiaries in the United States and/or other countries. SCILLC owns the rights to a number of patents, trademarks, copyrights, trade secrets, and other intellectual property. A listing of SCILLC's product/patent coverage may be accessed at www.onsemi.com/site/pdf/Patent-Marking.pdf. SCILLC reserves the right to make changes without further notice to any products herein. SCILLC makes no warranty, representation or guarantee regarding the suitability of its products for any particular purpose, nor does SCILLC assume any liability arising out of the application or use of any product or circuit, and specifically disclaims any and all liability, including without limitation special, consequential or incidental damages. "Typical" parameters which may be provided in SCILLC data sheets and/or specifications can and do vary in different applications and actual performance may vary over time. All operating parameters, including "Typicals" must be validated for each customer application by customer's technical experts. SCILLC does not convey any license under its patent rights nor the rights of others. SCILLC products are not designed, intended, or authorized for use as components in systems intended for surgical implant into the body, or other applications intended to support or sustain life, or for any other application in which the failure of the SCILLC product could create a situation where personal injury or death may occur. Should Buyer purchase or use SCILLC products for any such unintended or unauthorized application, Buyer shall indemnify and hold SCILLC and its officers, employees, subsidiaries, affiliates, and distributors harmless against all claims, costs, damages, and expenses, and reasonable attorney fees arising out of, directly or indirectly, any claim of personal injury or death associated with such unintended or unauthorized use, even if such claim alleges that SCILLC was negligent regarding the design or manufacture of the part. SCILLC is an Equal Opportunity/Affirmative Action Employer. This literature is subject to all applicable copyright laws and is not for resale in any manner.

PUBLICATION ORDERING INFORMATION

LITERATURE FULFILLMENT:
Literature Distribution Center for ON Semiconductor
19521 E. 32nd Pkwy, Aurora, Colorado 80011 USA
Phone: 303-675-2175 or 800-344-3860 Toll Free USA/Canada
Fax: 303-675-2176 or 800-344-3867 Toll Free USA/Canada
Email: orderlit@onsemi.com

N. American Technical Support: 800-282-9855 Toll Free
USA/Canada
Europe, Middle East and Africa Technical Support:
Phone: 421 33 790 2910
Japan Customer Focus Center
Phone: 81-3-5817-1050

ON Semiconductor Website: www.onsemi.com
Order Literature: <http://www.onsemi.com/orderlit>
For additional information, please contact your local Sales Representative

Mouser Electronics

Authorized Distributor

Click to View Pricing, Inventory, Delivery & Lifecycle Information:

[ON Semiconductor:](#)

[AX5043-1-TA05](#) [AX5043-1-TW30](#)